

LIGHTING

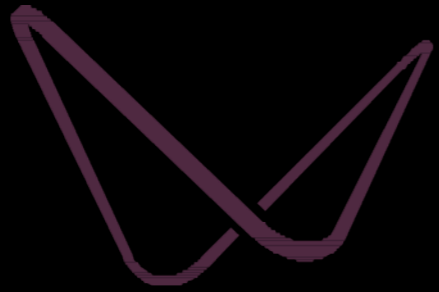

A.B.K

Lighting Manufacturing —



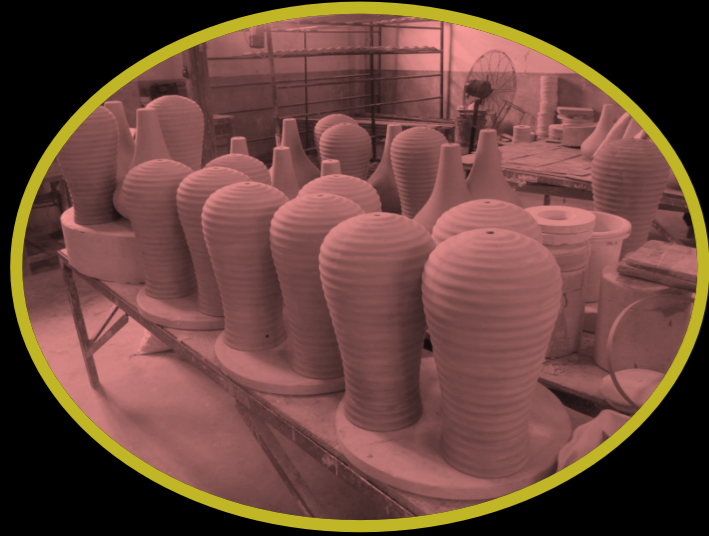



BLOB LAMP
Alabaster
H.510mm/20 1/4"
16" Bongo
Opal velvet shade
H.805mm/31 3/4"



BLOB LAMP
Tuxedo
H.510mm/20 1/4"
16" Bongo
Petrol satin shade
H.805mm/31 3/4"



LAMP SHADE GUIDE



At Porta Romana, we strive for perfection in every aspect of our designs, and that includes our Gold Standard lampshades – from the gauge of the wire to the position of the wattage label, our attention to detail means a Porta Romana lampshade is second to none.

Our silks, satins, linens and velvets are developed alongside the craftsmen and women who weave them, the transparencies of our linings have been created purposefully to give the right glow when our shades are lit, the seams of our shades are beautifully stitched and our packaging has been redesigned to ensure environmental harmony, and ease of unpacking. The ambition to create perfection is in our DNA, we want you to love what we do.



THORN BOWL
Olive
D.395mm/15 3/4"
H.267mm/10 1/2"



THORN VASE
Olive
D.252mm/10"
H.476mm/18 3/4"



COLOGNE LAMP
Cayenne with Decayed Gold Collar
H.220mm/8 3/4"
16" Straight Oval
Natural linen shade
H.490mm/19 1/2"



COLOGNE LAMP
Fawn with Decayed Gold Collar
H.220mm/8 3/4"
16" Straight Oval
Pine velvet shade
H.490mm/19 1/2"



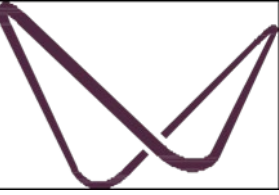

MANUFACTURING



SQUASH LAMP
Plum, H.290 mm / 11 1/2"
12" Top Hat Warm Grey
satin shade, H.605 mm / 23 3/4"

—GLB—55



WOODGRAIN LAMP
H.445 mm / 17 1/2"
13" Top Hat Manilla
silk shade, H.780 mm / 30 3/4"

—GLB—54



CABOCHON LAMP
Olive*, Charcoal, Turquoise, H.360 mm / 14 1/4"
14 1/2" Top Hat Papyrus
silk linen shade, H.745 mm / 29 1/4"

—GLB—59



Thread Lamp
Amber
GLB32



Blob Lamp
Turquoise
GLB31



Chianti Lamp
Bronze with Nickel base
GLB13



Rockefeller Lamp
Mayan Gold with Slate base
SLB50



Small Salperton Lamp
Decayed Gold
SLB47S

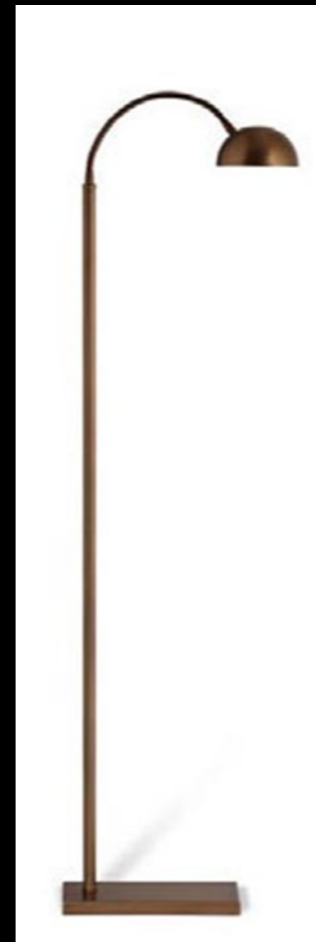

LIGHTING

has always been the driving force

ABK recognise that well unique lighting products can enhance and transform an interior design scheme. An knowledge of various client market sectors shape initial design concepts which then become sketches, technical drawings, 3D renderings and prototypes – all produced in our factory with highest levels

"There is no limitation to our aspirations when it comes to developing bespoke light fittings with the abk design team. Their "Can Do" approach combined with great manufacturing knowledge and attention to detail allows us to create unique fittings for our projects confident that commercial standards, efficiencies and budgets are met."

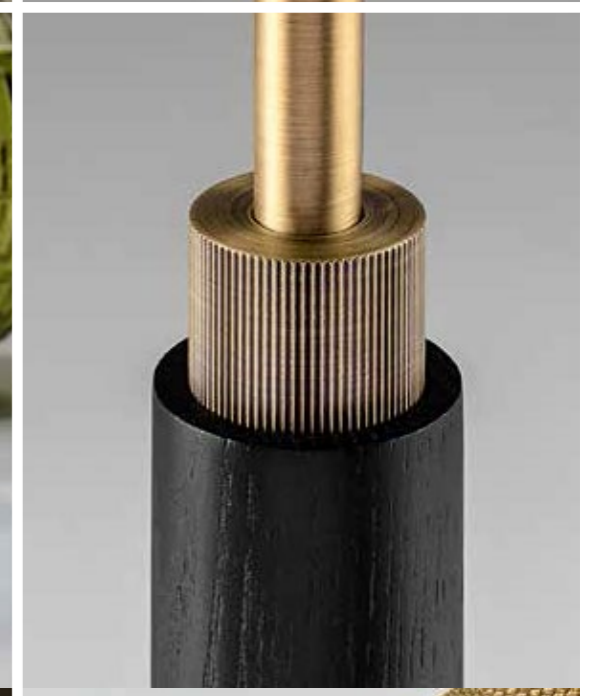

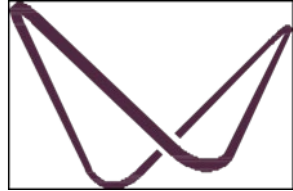

A wide scope of

MANUFACTURING

skills and capabilities

abk are experts at manufacturing all kinds of lighting for both high volume production , abk are able to produse manufacturing techniques with and aesthetic design know-how to come up with eye catching, high quality products at suitable prices for the market.

At their production facilities in China, quality management is paramount to (abk) success so whether it be basic metal working with steel and aluminium, casting brass, plating and painting, turning wood, mouth blowing glass or modelling ceramic moulds, abk focus is always on creating the best possible product for their customers.

“We have worked with Chelsom on a number of hotel projects including Crown plaza dahran and almadena in saudia arabia, they are our first port of call when it comes to lighting. our capacity to deliver on a projects, combined with their knowledge, technical capabilities and flexibility means that they are always able to surpass our expectations whilst working within budgets.”



Installation process01



Installation process02



Installation process03



Installation process04



Installation process05



Installation process06



Copyright 2018 Chelsom Ltd

Manufacturers of

BESPOKE

one-off statement pieces or multi-unit production runs

ABK expertise in manufacturing beautiful and elegant lighting collections in-house extends to a huge variety of bespoke products. Renowned for their flexibility, technical capabilities and ability to work collaboratively with some of the world's leading designers, ABK have the skills to enhance any interior scheme

by taking a client's vision, adding technology and value engineering and making it a reality.

Whether a one-off central public area feature light or a long production run, ABK produce 3D technical drawings and renderings to give clients full confidence in their concepts before producing prototypes and final manufacturing runs.

you can depend on (abk) for a quality product, timely delivery and with the end result being a satisfied client, it makes our efforts worthwhile."



CROWN PLAZA

Project: Crown plaza al madenah
Client: Al rajhe Hotel Group.

Copyright 2018 Chelsom Ltd



REGENT

Project: Seven Seas Explorer.
Client: Regent Seven Seas Cruises.
Designer: Tillberg Design.



MONDRIAN

Project: Mondrian London at Sea Containers.
Client: Morgans Hotel Group.
Designer: Tom Dixon Design Research Studio.

Copyright 2011 8
Chelsom Ltd



CROWN PLAZA

Project: Crown plaza al madenah
Client: Al rajhe Hotel Group.

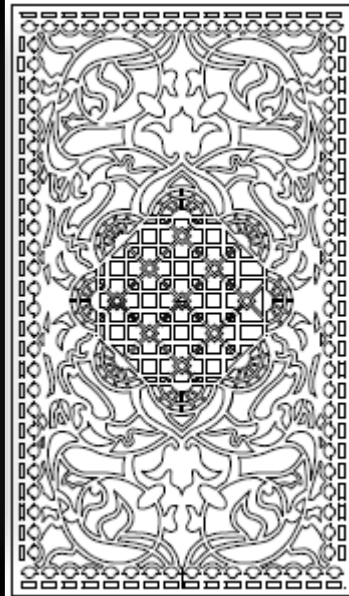
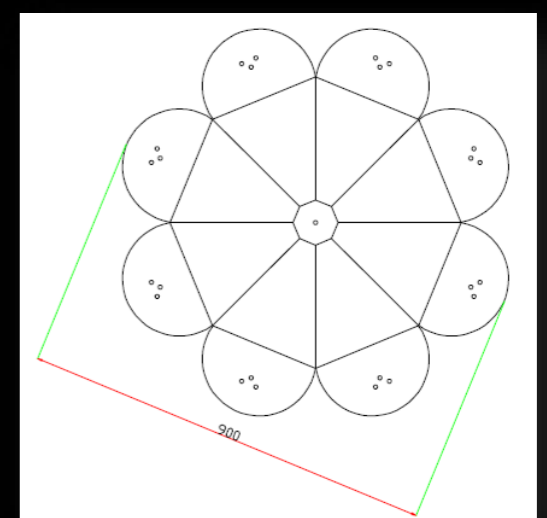
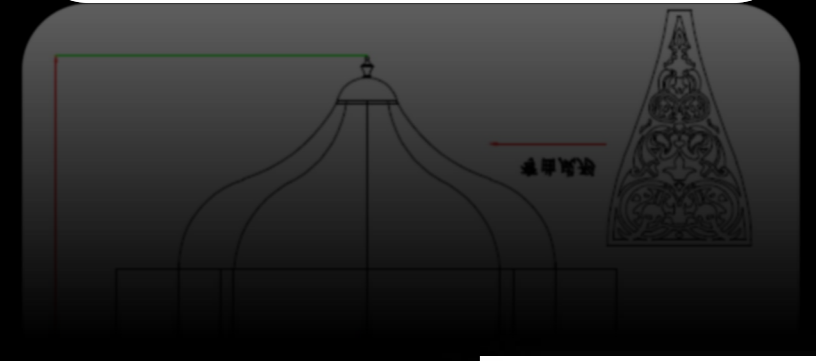
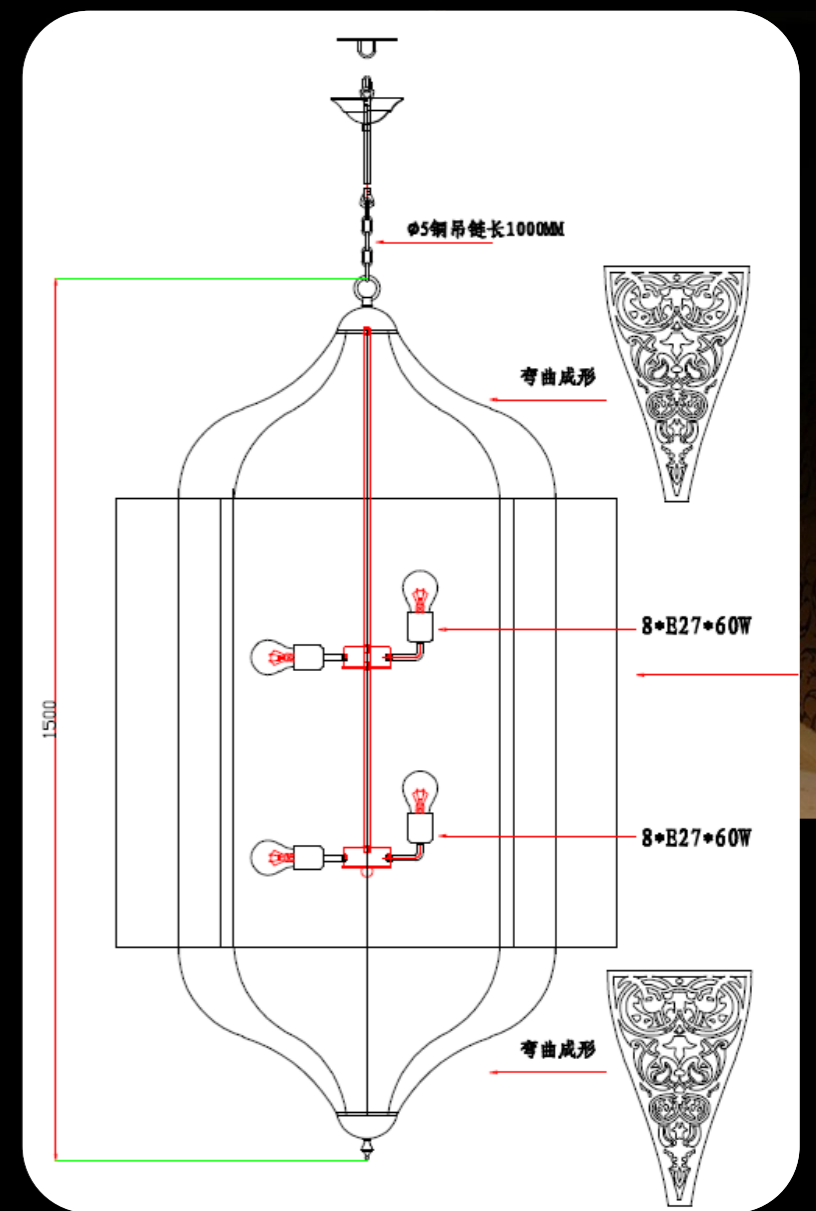

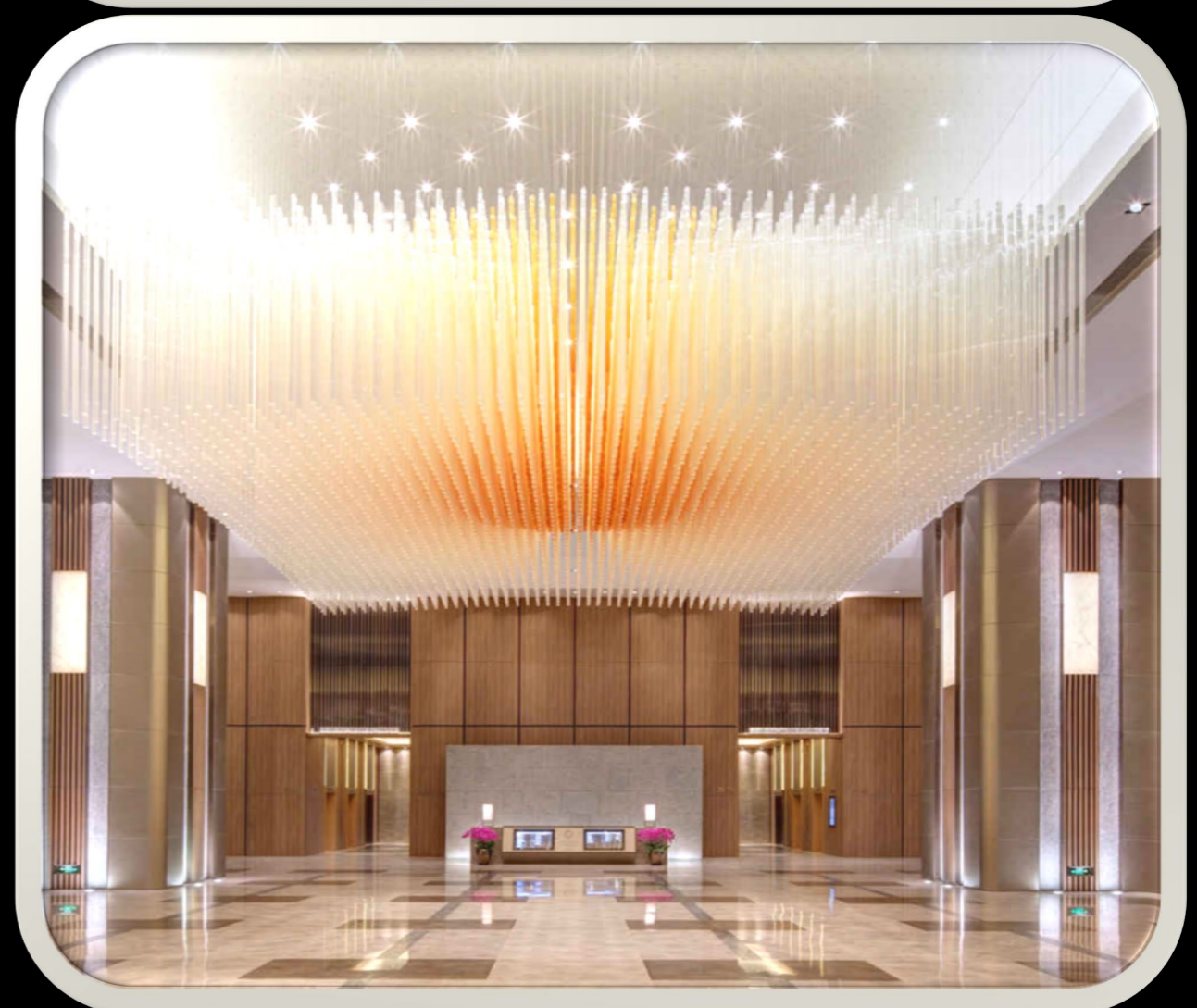
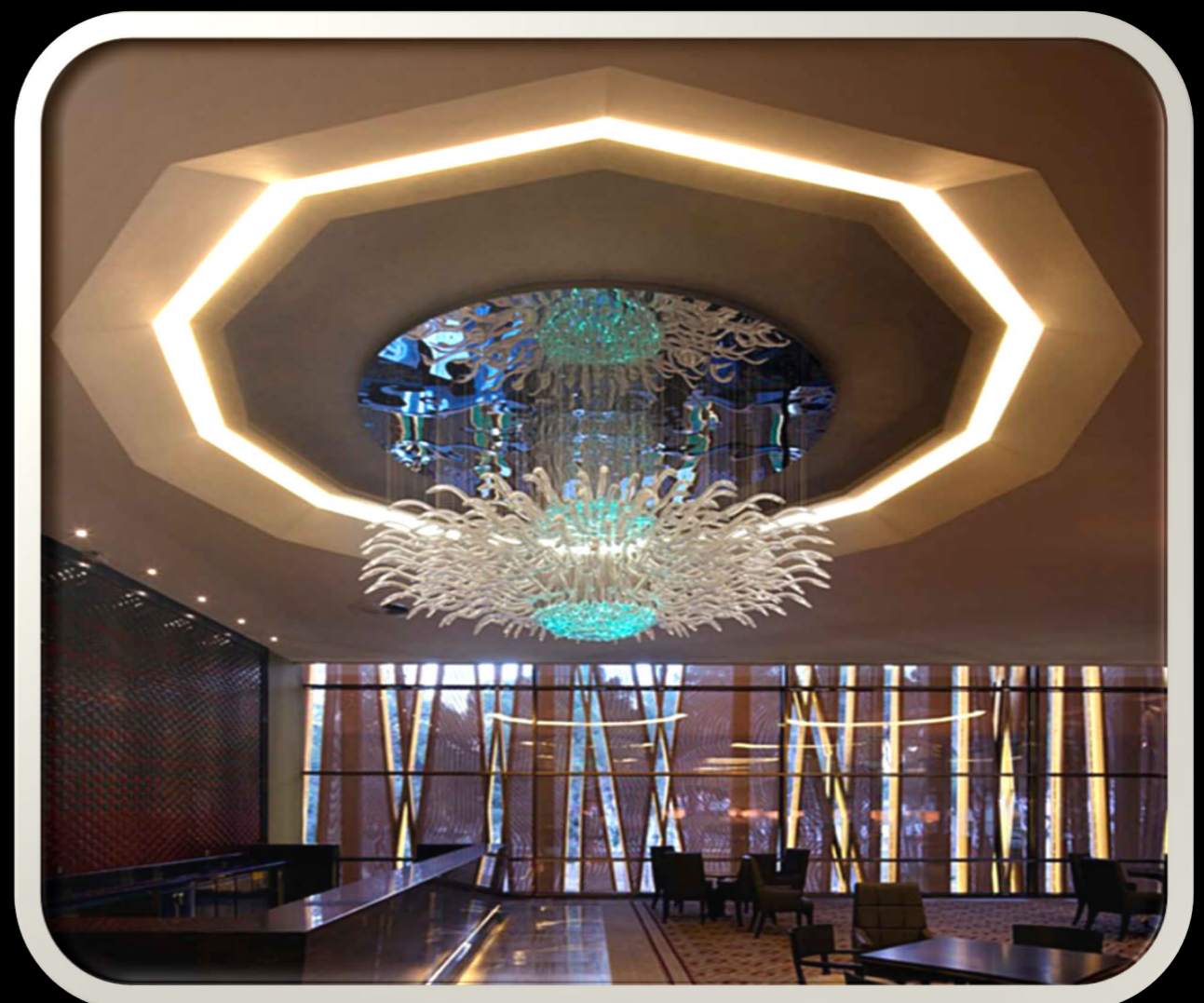

Lighting supply partner to the

HOSPITALITY

market worldwide

CROWN PLAZA

Project: Crown plaza al madenah
Client: Al rajhe Hotel Group.

we have the experience in hospitality lighting, (abk) extensive market knowledge means they offer one of the best hotel lighting prices in . With the hospitality sector in mind at concept stage, high quality, low energy.

abk work collaboratively with hotel operators, interior designers, procurement groups and contractors making them a fundamental part of the team responsible for bringing projects to a successful conclusion. By understanding lead time requirements, budget constraints and having wide experience in onsite engineering, abk truly are experts in this specialist field.

"What amazing service! Your technical quality and capabilities are the best I've seen."



CROWN PLAZA

Project: Crown plaza al madenah
Client: Al rajhe Hotel Group.

Copyright 2018 Chelsom Ltd



CROWN PLAZA

Project: Crown plaza al madenah
Client: Al rajhe Hotel Group.



CROWN PLAZA

Project: Crown plaza al madenah
Client: Al rajhe Hotel Group.

Copyright 2018 Chelsom Ltd

Designing unique lighting for BARS AND RESTAURANTS

around the world

Great restaurants are defined by their ambience and the right ambience is created by good lighting. Indeed well designed decorative wall and ceiling lighting will often form the centrepiece of bar or restaurant interior schemes. abk offer many such collections within the standard range or will work closely with interior designers to bring their custom lighting concepts to life

"abk level of expertise makes working together an absolute joy. Whether it is the way in which they take our designs and translate them into considered and beautifully manufactured products or their ability to come up with seamless solutions for manufacture, installation or maintenance."



Copyright 2018 Chelsom Ltd



Experts in

CLASSICAL LIGHTING

abk are experts in manufactory all traditional lighting styles. With the capacity to create a wide range of high-quality traditional lighting products, abk broad manufacturing capabilities incorporate the very best materials and finishes to ensure they are truly sympathetic to period and classical styles. Whether for an original heritage building or to add a more classical twist within a contemporary project, abk has the knowledge and expertise to meet your classical lighting requirements.



THE SAVOY
Project: The Savoy, London.
Client: Fairmont Hotels.
Designer: Pierre-Yves Rochon & Reardon Smith Architects.

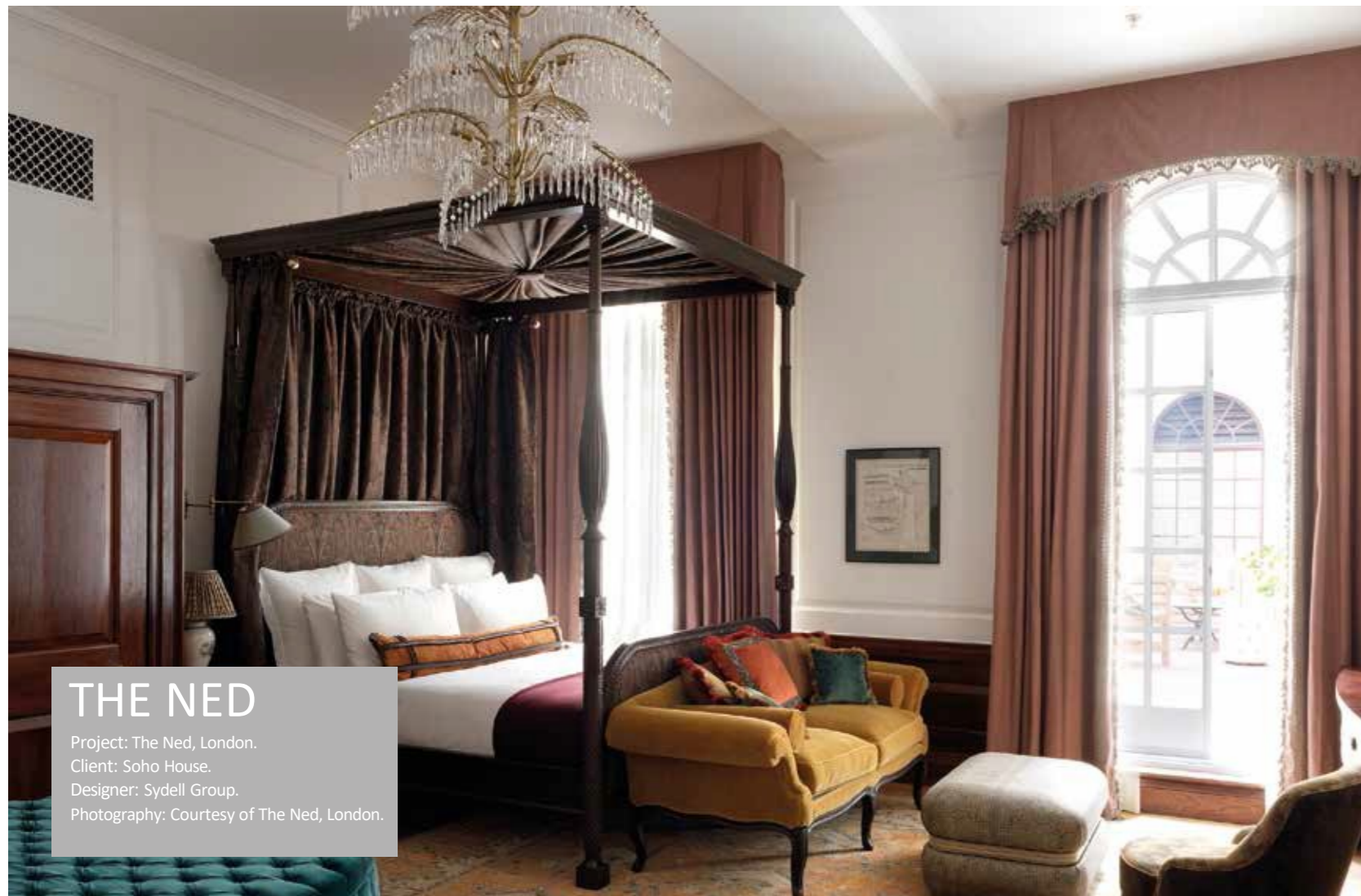

THE NED
Project: The Ned, London.
Client: Soho House.
Designer: Sydell Group.
Photography: Courtesy of The Ned, London.



Copyright 2018 Chelsom Ltd

Masters in the

RESTORATION

of period lighting

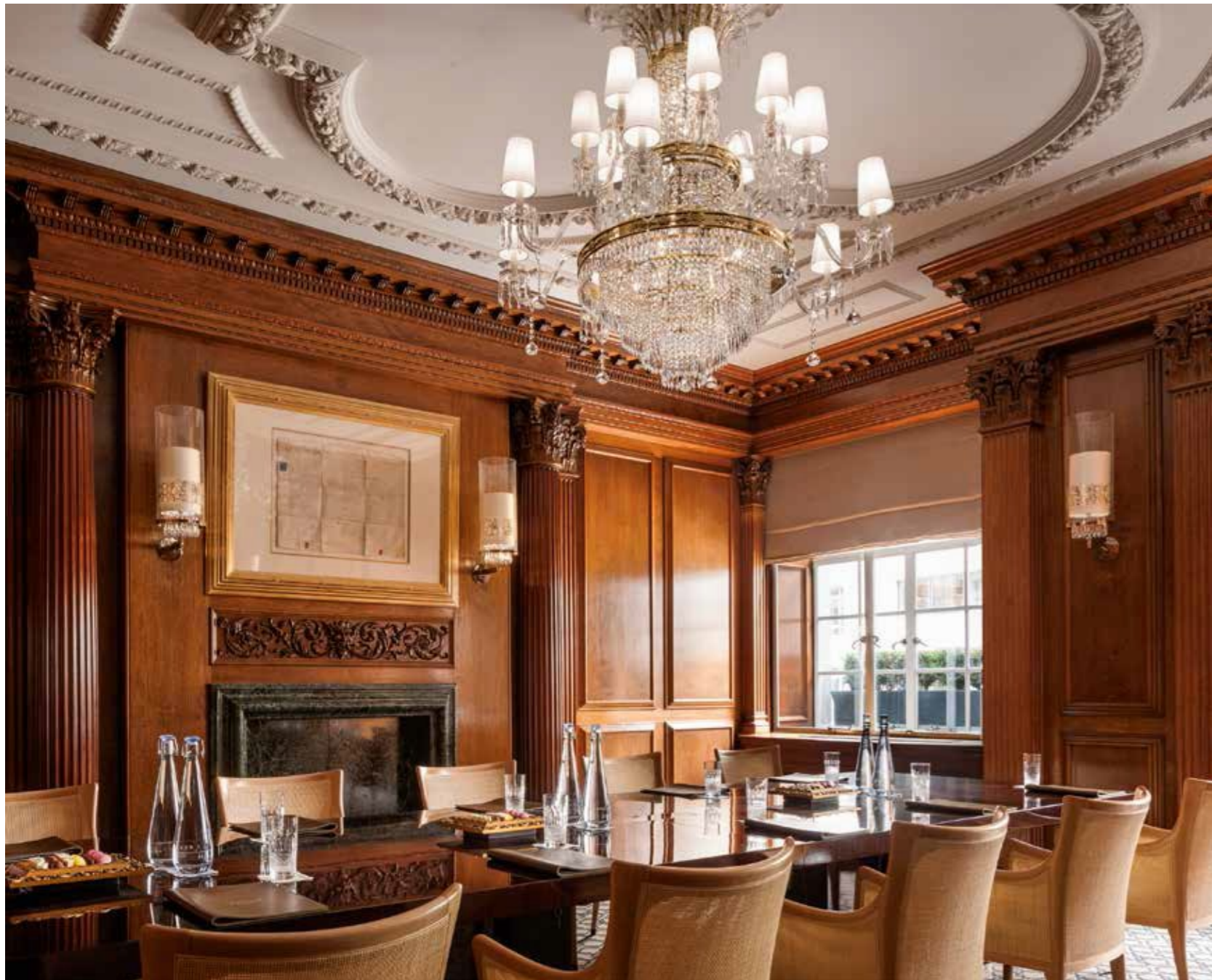

Expertise in the latest TECHNOLOGY

for hospitality and marine lighting

Whereas aesthetics has primarily driven the pace of change in decorative lighting designs over the years, rapidly advancing technology has become equally important in ensuring specifiers are working with the most up to date products. abk operate rigorous testing procedures to select the best performing LEDs and work only with the most reputable LED chip and retrofit lamp manufacturers. When testing and selecting LED chips, the following criteria are considered:

Evaluation of latest technology to give increased lumen performance

Minimum lifetime operating cost for the end user

LED chip performance over its entire life Optimum light effect considering wattage and colour temperature

At abk factories in the China, continual investment means the latest manufacturing and testing equipment drives on the quality of the product. In-house photometric testing guarantees colour temperatures and Colour Rendering



Testing LED chips and control gear.

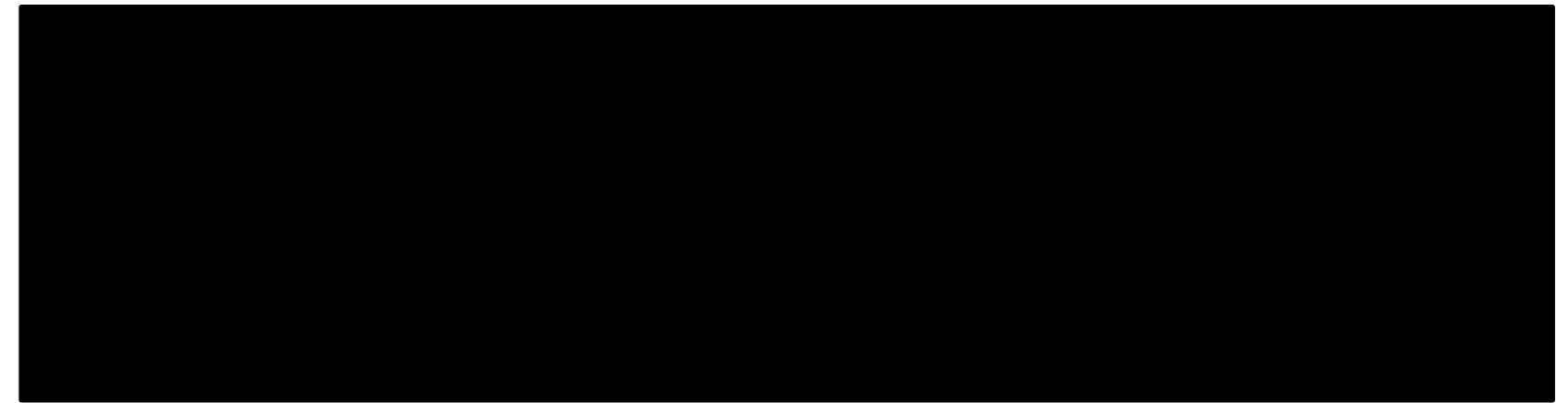

Bespoke integrated LED technology.



In-house photometric testing.



LED strip manufacturing.

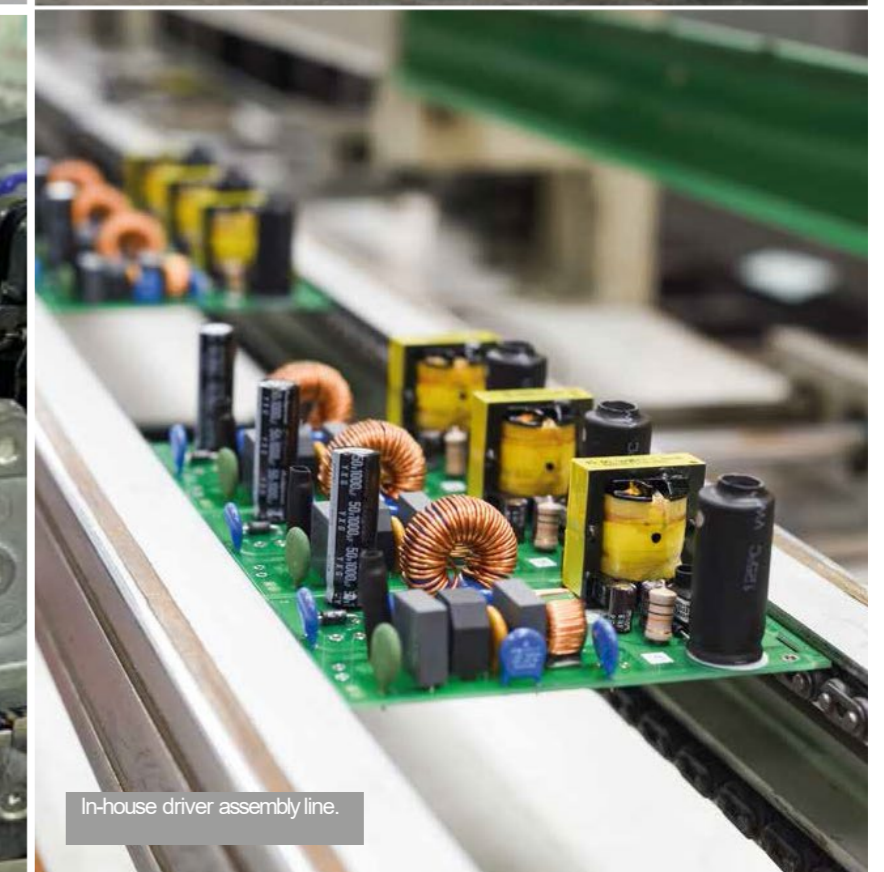

In-house driver assembly line.

Copyright 2018 Chelsom Ltd

DIMMING

To ensure optimum ambience within any interior scheme, light levels should be controllable through dimming systems. Dimmable lamps can be operated from rotary dimmer switches within the product itself or from remote wall-mounted control panels. There exists an extremely wide range of lamp dimming protocols but the crucial issue is ensuring compatibility between lamp type, control gear and the dimmer itself.

Most Popular Dimming Protocols



Mains/Phase Dimming

There are two types of mains dimming – leading edge and trailing edge. As perhaps the longest established of the dimming protocols, there is the widest variety of control gear and dimmers existing in the marketplace. Consequently, ensuring compatibility with the latest light sources is essential and the Chelsom Technical team is available to offer support. Connected to mains cable only, this is a simple system to install for the contractor.

1-10V Dimming
 1-10V dimming (also known as 0-10V dimming) is an analogue dimming method which requires both mains power and signal wires between the 1-10V dimmer and the driver. This type of dimming is possible only with products which have integrated LED light sources and compatible driver.

DALI Dimming
 DALI dimming is a digital programmable system, usually installed in large commercial properties. The system allows the control of individual luminaires from one central control panel. It requires specialist installation and commissioning. DALI requires mains power and signal wires between the DALI dimmer and compatible driver.

PLEASE CONSULT CHELSOM FOR EXPERT ADVICE ON ALL YOUR DIMMING REQUIREMENTS.

LAMPS

Retrofit LED

Lamp technology has developed possibly faster in the last 10 years than at any time since Thomas Edison invented his first electric light bulb. abk constantly embrace the latest developments to ensure the hospitality and marine markets work with the most energy efficient and aesthetically pleasing light sources. Today's lamps use 90% less energy than old incandescents, last up to 25 times longer, give off almost no heat and significantly reduce maintenance costs. The latest retrofit lamps from abk have almost 360° light output and a 2700K warm white colour temperature with instant start and good dimmability, compatible with both leading and trailing edge phase dimming controls.

Incandescent	Halogen	Compact Fluorescent	First Generation LED	Latest LED
60W	46W	15W	12W	7W
1000 Hrs	2000 Hrs	6000 Hrs	15,000 Hrs	25,000 Hrs
2700K	2700K	2700K	2700K	2700K
600 Lumens	630 Lumens	900 Lumens	806 Lumens	810 Lumens

Estimated information for comparison only



E27 Filament Squirrel Cage

E27 Filament Globe

E27 Filament Cigar

E27 Filament Small Cigar

E14 Filament Golf Ball

GUESTROOM & BATHROOM



GUESTROOM & BATHROOM



Lunar 32 Lunar 34 Chelsea 35 Roma 38 Radar 40 Capri 42 Madison 45



LED Groove 108 LED Classic 109 LED Focus VA 110 LED Reading VA 112 Rock Desk Lamp 114 Desk Hub Cap 116 Desk Study 118



Shaftesbury 48 Washington 51 Rock 54 Rock 56 Tokyo 58 Seed Glass 60 Seed Glass 62



Desk Canopy 120 Crane 121 Motion 122 Charging 123 Traveller 126 Piazza 127 Berlin 128



Seed Glass 64 Boston 65 Richmond 68 Chicago 70 Metro 74 Saucer 77 Balance 80



Check In 130 Box 132 Crossover 134 Scroll 136 Exec 138 Trip 140 Adjust 142



Manhattan 82 Park 84 Swing Reading 86 Swing Brass 88 Swing Chrome 89 Biblio 90 Townhouse 92



Angle VA 144 Downtown VA 146 Vinyl VA 148 Weekend VA 149 Guest VA 150 Avenue VA 152 Project VA 154



Broadway 94 Direct 95 LED Revolution 96 LED Dock 99 LED Dock 104 LED Hotel 105 LED Knurl 106



Plaza VA 157 Interiors VA 158 Urban VA 160 Bathroom Mirror VA 162 Bathroom Deluxe 164 Bathroom Deluxe 165 Bathroom VA 166

Materials:
Steel, stone
and glass.

Finishes: Brushed Brass (BRB) with Natural stone
and Opal glass – see overleaf for alternative finish,
Satin Black (BL) with Grey stone and Smoke glass.

Features: Stone heavy bases and backplates sit within curved metal
surrounds and glass globes are secured with threaded metal rings to
ensure safety and durability. Wall lights can be fitted as up or down lights.

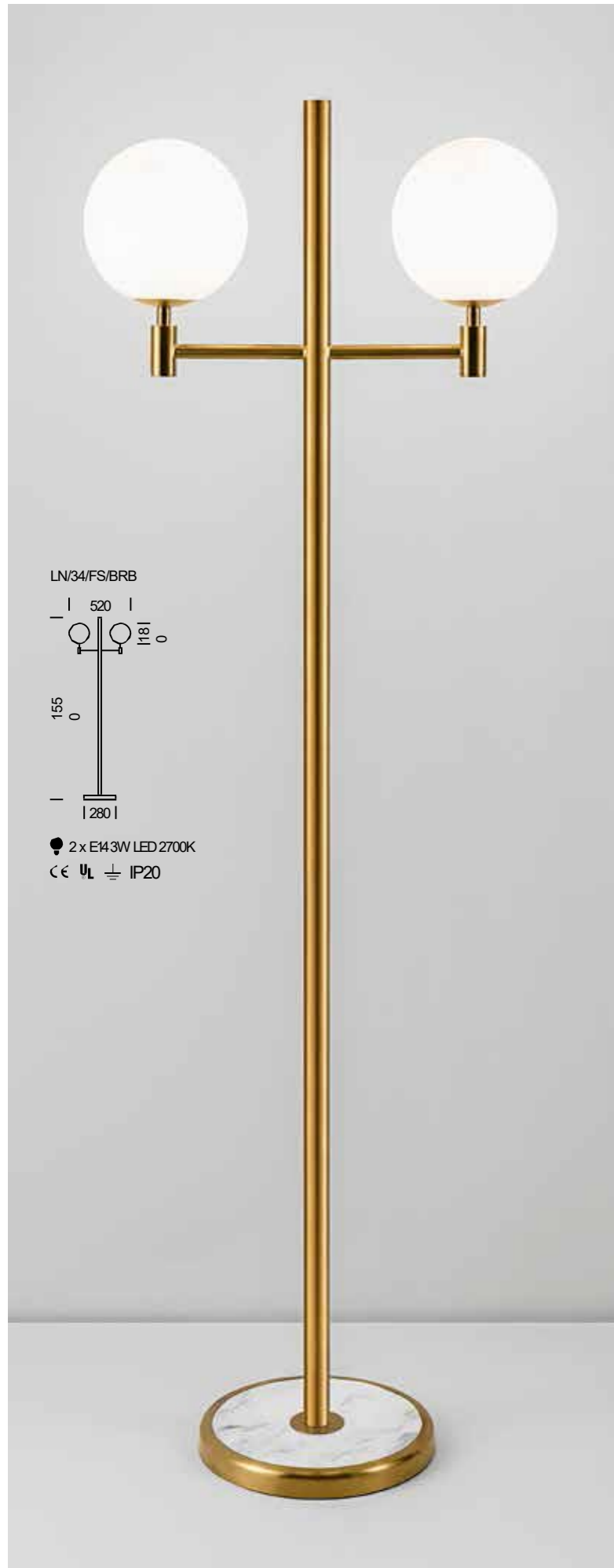

LN/34/FS/BRB

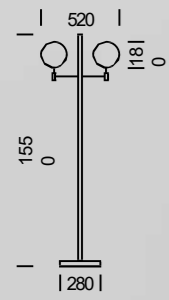

2 x E14 3W LED 2700K
CE U_L IP20



LN/34/W1/BRB

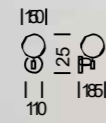

1 x E14 3W LED 2700K
CE U_L IP20



LN/34/W2/BRB

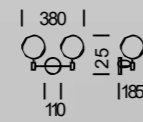

2 x E14 3W LED 2700K
CE U_L IP20



LN/34/WV/BRB

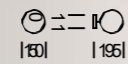

1 x E14 3W LED 2700K
CE U_L IP20



LN/34/TL/BRB



1 x E14 3W LED 2700K
CE U_L IP20

Materials: Steel, stone and glass.

Finishes: Satin Black (BL) with Grey stone and Smoke glass. See previous pages for alternative finish - Brushed Brass (BRB) with Natural stone and Opal glass.

Features: Stone heavy bases and backplates sit within curved metal surrounds and glass globes are secured with threaded metal rings to ensure safety and durability. Wall lights can be fitted as up or down lights. THE RANGE IN THIS FINISH OPTION IS PRICED WITH AND COMES COMPLETE WITH LAMPS AS SHOWN.



Materials: Steel and fabric.

Finishes: Black Bronze (BB) or Polished Chrome (C) with Oyster fabric diffusers.

Features: Rectangular metal frame shades with Oyster fabric diffusers are surrounded with an asymmetrically positioned square tube feature. Table lamps have knurled rotary dimmer switches. See overleaf for matching wall and floor lamps.



Materials: Steel and fabric.
 Finishes: Black Bronze (BB) or Polished Chrome (C) with Oyster fabric diffusers.

Features: Rectangular metal shades with Oyster fabric diffusers are surrounded with an asymmetrically positioned square tube feature. Wall lights can be vertically or horizontally mounted and there is an option with an additional switched LED reading light. See previous page for matching table lamps.



CL/15W1/LED/BB
 | 190 | | 170 |
 | 42 |
 1x E27 7W LED 2700K
 plus 1x LED 1W 2700K
 CE U L IP20



CL/15FS/BB
 | 240 |
 | 160 |
 | 200 | | 400 |
 1x E27 8W LED 2700K
 CE U L IP20



CL/15W1/BB
 | 190 | | 170 |
 | 30 |
 (Vertically mounted.)
 1x E27 7W LED 2700K
 CE U L IP20



CL/15W1/C
 300 | 17 |
 (Horizontally mounted.)
 1x E27 7W LED 2700K
 CE U L IP20



CL/15W1/LED/C
 | 190 | | 170 |
 | 42 |
 1x E27 7W LED 2700K
 plus 1x LED 1W 2700K
 CE U L IP20

Copyright 2018 Chelsom Ltd





RM/9/P
 | 100 |
 | 400 |
 Min
 Max
 | 245 |
 Weight 2kg

1x E27 8W LED 2700K
 CE U L IP20



RM/9/W1
 | 120 |
 | 200 |
 | 171 |
 | 26 |
 | 60 |

1x E27 7W LED 2700K
 CE U L IP20



RM/9/FS
 | 440 |
 | 17 |
 | 15 |
 | 300 |

1x E27 8W LED 2700K
 CE U L IP20

Material:
Steel.

Finish: Golden
Bronze with
Satin Black.

Features: Tapered perforated metal shades with internal PVC Opal
diffusers give a dramatic and softly diffused light effect. The table
lamp has a directional shade and integral push switch in the base.



RM/9/TL
 | 265 |
 | 80 |
 | 185 |

1x E27 7W LED 2700K
 CE U L IP20

Copyright 2018 Chelsom Ltd

Material: Steel.
Finish: English Brass with Satin Black.

Features: Shallow perforated metal coolie shades are supported by detailed knurled lampholder covers and contain LED squirrel cage filament lamps. RA/4/DL and RA/5/W1 have directional heads and the table lamp has a knurled rotary dimmer switch. RA/4/W1 can be ceiling mounted. THE RANGE IS PRICED WITH AND COMES COMPLETE WITH LAMPS AS SHOWN.



Copyright 2018 Chelsom Ltd

CP/24/W1/BB
 | 250 | | 300 |
 | 15 | | 0 |
 LED 8W 2700K
 CE IP20
 (For UL please enquire.)



CP/24/W1/BRB
 | 250 | | 300 |
 | 15 | | 0 |
 LED 8W 2700K
 CE IP20
 (For UL please enquire.)



Materials:
 Steel and
 glass.

Finishes: Brushed Brass
 (BRB) or Black Bronze (BB)
 with frosted Opal glass.

Features: Heavily ribbed Opal glass shades are secured with metal threads onto knurled decorative double-stepped caps. The table lamp has a rotary dimmer switch and wall lights can be installed as up or downlighters. Light sources are integral dimmable warm white LED. See overleaf for matching ceiling fittings.

CP/24/TL/BRB
310	
51	
180	
 LED 8W 2700K
 CE IP20
 (For UL please enquire.)



CP/24/TL/BB

Copyright 2018 Chelsom Ltd

Materials:
Steel and
glass.

Finishes: Brushed Brass
(BRB) or Black Bronze (BB)
with frosted Opal glass.

Features: Heavily ribbed Opal glass shades are secured onto knurled decorative double-stepped caps. Light sources are dimmable. CP/24/P has a fixed suspension rod which can divide into three connectable parts (250mm, 400mm or 600mm). See previous pages for matching table and wall lights.

Steel.

Bronze with
English Brass.

outer shade and Natural Parchment inner cylinder shades – further shade options are shown overleaf. Black Bronze metalwork has contrasting accents in English Brass.

CP/24/4/BRB

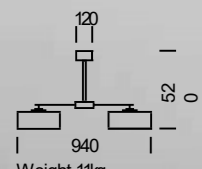

Weight 11kg
4 x LED 8W 2700K
CE IP20
(For UL please enquire.)



CP/24/P/BB

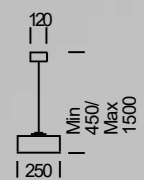

Weight 2kg
LED 8W 2700K
CE IP20
(For UL please enquire.)



CP/24/FF/BB

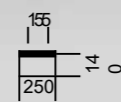

LED 8W 2700K
CE IP20
(For UL please enquire.)



MD/ 8/ TL2 with optional
shades QMD/ 2/SM and
2x QMD/ CYL/NP

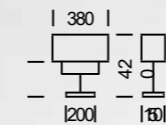

2 x E27 7W LED 2700K
CE IP20

Copyright 2018 Chelsom Ltd

Material: Steel. Finish: Black Bronze with English Brass. Features: Substantial square section arms support twin lamps for double wall light and floor lamp.

Outer rectangular or square shade options include Smoke transparent (SM) or Black chintz with Champagne Gold liner (BG) – with other options shown at back of catalogue. Inner cylinder shades are in Natural Parchment (NP). Decorative filament lamps can be used in place of inner shades. Black Bronze metalwork has contrasting accents in English Brass.

MD/8/W2 with optional shade QMD/2/BG

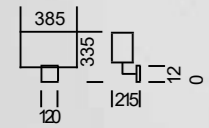

2 x E27 7W LED 2700K
CE U L IP20



MD/8/P with optional shades QMD/P/ SM and QMD/CYL/L/NP

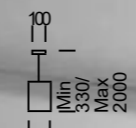

Weight 0.2kg
1 x E27 7W LED 2700K
CE U L IP20



MD/8/W1 with optional shades QMD/W1/SM and QMD/CYL/NP

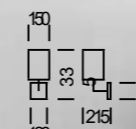

1 x E27 7W LED 2700K
CE U L IP20



MD/8/FS2 with optional shades QMD/FS/ SM and 2 x QMD/CYL/L/NP

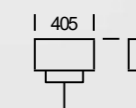

2 x E27 7W LED 2700K
CE U L IP20



Materials: Steel (with brass for EBR finish).

Finishes: Black Bronze with English Brass (BB/EBR). See overleaf for Polished Chrome (C) option.

Features: A double arm design with wall and table options shown here plus a floor lamp and single wall light shown overleaf. All models have a central knurled section and the table lamp is operated by a rotary dimmer switch.

SH60/ W2/BB/EBR with optional shades QSH6/BG

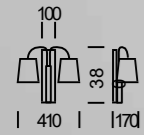

2 x E27 7W LED 2700K
 CE U_L IP20



SH60/ TL2/BB/EBR with optional shades QSH6/BG

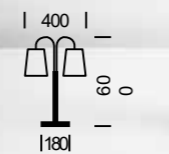

2 x E27 7W LED 2700K
 CE U_L IP20

Project: SHAFTESBURY at The Grand Hotel, Lytham St. Annes.
 Designer: In-house Design Team.



Copyright 2018 Chelsom Ltd

brass for EBR finish.
See previous pages).

Black Bronze with English Brass
(BB/EBR) – see previous pages.

wall light and other options shown on the previous
pages. All models have a detailed central knurled section.



Materials:
Steel and
brass.

Finish: Black
Bronze with English
Brass (BBE/BR).

Features: Washington models feature knurled detailed centre
sections in the heavy upright columns. Further colour accents are
provided by oversized contrasting washers on the bases or backplate.

WT/23FS/BB/EBR with
optional shade QST/22/BG

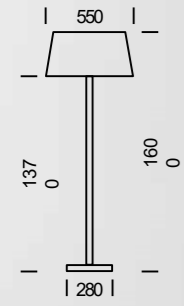

1x E27 8W LED 2700K
CE U_L IP20



WT/23/W1/BB/EBR with
optional shade QST/7/BG

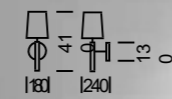

1x E27 7W LED 2700K
CE U_L IP20

WT/23/TL/BB/EBR with
optional shade QST/16/BG

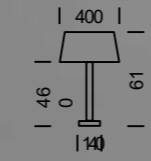

1x E27 7W LED 2700K
CE U_L IP20



Project: ROCK at Hilton Diagonal Mar Barcelona.
 Designer: The Hickson Design Partnership Ltd.



Materials:
 Steel and
 natural stone.

Finish: Black Bronze
 metalwork with English Brass
 accents and natural stone.

Features: Shade swivels and adjusts. Refined curved column
 sits on an angled plinth and heavy natural stone block
 ensuring good stability. See overleaf for more designs.



DL/16/BB/EBR with optional
 shade QDL/7/LINEN NAT

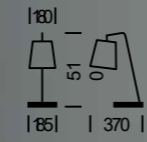

1x E27 7W LED 2700K
 CE U L IP20

Steel with natural stone.

Bronze metalwork with natural stone.

sit on square detailed plates and heavy natural stone cubes ensuring good stability.



RK/ 10' W1 with optional shade QCY/6/E27/LINEN NAT
 163 | 34 | 124 | 0
 120 | 250 |
 1x E27 7W LED 2700K
 CE U L IP20



RK/ 10' TL with optional shade QCY/ 12/LINEN NAT
 310 |
 120 |
 1x E27 7W LED 2700K
 CE U L IP20

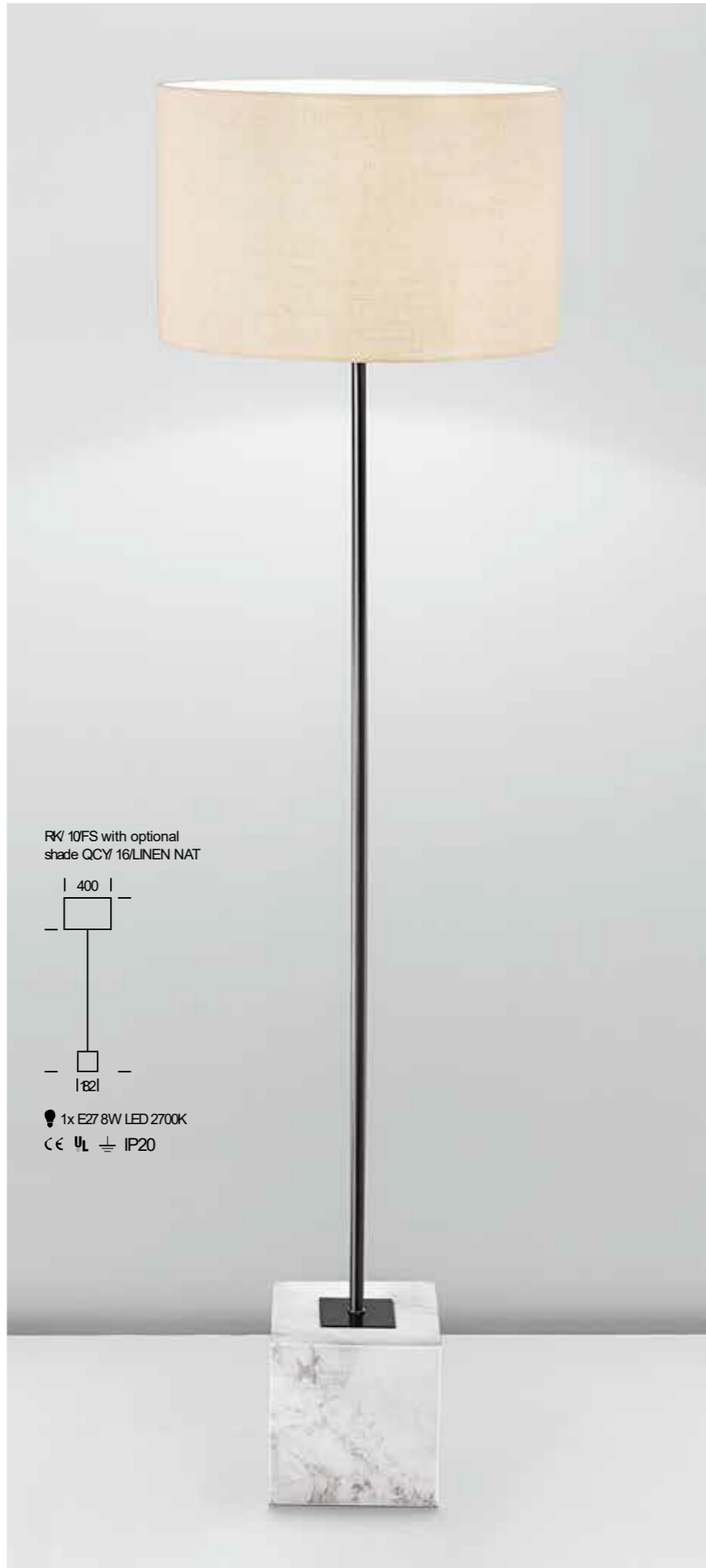

RK/ 10FS with optional shade QCY/ 16/LINEN NAT
 400 |
 182 |
 1x E27 8W LED 2700K
 CE U L IP20



RK/ 11/TL with optional shade QCY/ 10/LINEN NAT
 250 | 370 |
 120 | 120 |
 1x E27 7W LED 2700K
 CE U L IP20

Copyright 2018 Chelsom Ltd

Materials:
Steel and
glass.

Finish: Brushed
Brass and Smoke
seed glass.

Features: Smoke seed glass globes enclose warm white LED filament lamps. The pendant has an optional Oyster fabric inner shade and is supplied with a fixed suspension rod which can divide into three connectable parts (250mm, 400mm, or 600mm). THE RANGE IS PRICED WITH AND COMES COMPLETE WITH LAMPS AS SHOWN.



Copyright 2018 Chelsom Ltd

Materials: Steel and glass.
 Finish: Black Bronze (BB) with Clear seed glass.

Features: Thick, Clear seed glass columns are firmly held between silicone gaskets and metal turnings. These robust pieces feature random bubbles in clear glass which pick up the fall of light from shades. SG/24/P/BB gives good downlight and is ideal for bedside tables or other areas needing an ambient glow. See the following pages for further design options.



SG/24/P/BB

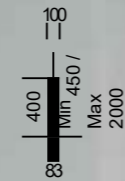

Weight 1kg

1x GU10 7W LED 2700K
 CE U L IP20



SG/24/W1/BB with optional shade QFD/8/OY

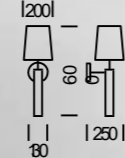

1x E27 7W LED 2700K
 CE U L IP20

SG/24/FS/BB with optional shade QST/22/OY

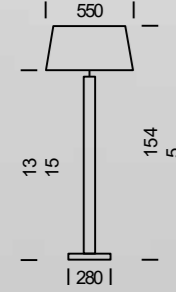

1x E27 8W LED 2700K
 CE U L IP20



SG/24/TL/BB with optional shade QST/18/OY

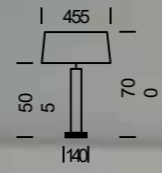

1x E27 7W LED 2700K
 CE U L IP20

Copyright 2018 Chelsom Ltd

Materials: Steel and glass. Finishes: Black Bronze (BB) with Clear seed glass. See overleaf for Polished Chrome (C) option.

Features: Thick, Clear seed glass outer shades are capped top and bottom with metal channels and feature random bubbles which pick up the glow of light from internal Hemp shades (see back of catalogue for alternative shade fabrics). Pendant SG/25/P/BB is supplied with a fixed suspension rod which can divide into three parts (250mm long, 400mm long, 600mm long) allowing various overall drops.



Copyright 2018 Chelsom Ltd

Steel and glass.

Clear seed glass. See previous page for Black Bronze (BB) option.

pick up the glow of light from internal Oyster shades (see back of catalogue for alternative shade fabrics). SG/25/P/C is supplied with a fixed suspension rod (see previous page).

Materials: Steel (with brass for EBRfinish).

Finishes: Black Bronze with English Brass (BB/EBR), Polished Chrome (C).

Features: Stepped bases with colour co-ordinated push switches support crossed columns with decorative end turnings.

Shades: Other fabric options available for these bespoke shades.

See following pages for matching wall and floor lamps.

BOSTON



Copyright 2018 Chelsom Ltd

Materials:
Steel (with brass
for EBRfinish).

Finishes: Black Bronze with
English Brass (BB/EBR),
Polished Chrome (C).

Features: Stepped floor standard
bases support crossed columns
with decorative end turnings.

Shades: Other fabric
options available for
these bespoke shades.

See previous page
for matching
table lamps.



BO/ 22/W1/BB/EBR with
optional shade Q22/W1/BG

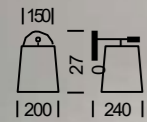

1x E27 7W LED 2700K
CE UL IP20



BO/ 22/W1/C with optional
shade Q22/W1/GM



BO/ 22/FS/ C with optional
shade Q22/FS/LINEN AUB

Copyright 2018 Chelsom
Ltd



BO/ 22/FS/BB/EBR with
optional shade Q22/FS/BG

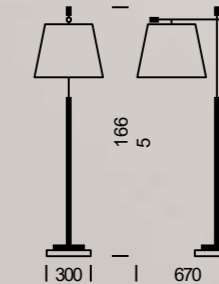

1x E27 8W LED 2700K
CE UL IP20

Materials:
Steel and
fabric.

Finishes: Brushed
Brass (BRB) or
Brushed Nickel (BN).

Features: Internal integral LED light sources allow very shallow shades for unique proportions and excellent diffused light distribution. The range is complete with off white fabric shades secured on top with decorative grooved discs. Table and floor lamps include dimmer switches (wall light dimmable remotely).



RI/23/FS/BN
| 500 |
— —
1450
— —
| 300 |
LED 8W 2700K
CE ± IP20
(For UL please enquire.)



RI/23/W1/BN
| 250 | | 310 |
— — — —
190
— —
LED 5W 2700K
CE ± IP20
(For UL please enquire.)



RI/23/TL/BN
| 350 |
— —
480
— —
| 200 |
LED 6W 2700K
CE ± IP20
(For UL please enquire.)



RI/23/FS/BRB
| 500 |
— —
1450
— —
| 300 |
LED 8W 2700K
CE ± IP20
(For UL please enquire.)



RI/23/W1/BRB
| 250 | | 310 |
— — — —
190
— —
LED 5W 2700K
CE ± IP20
(For UL please enquire.)



RI/23/TL/BRB
| 350 |
— —
480
— —
| 200 |
LED 6W 2700K
CE ± IP20
(For UL please enquire.)

Copyright 2018 Chelsom Ltd

Materials: Steel (with brass for EBR finish) with acrylic diffuser.

Finishes: Black Bronze (BB), Polished Chrome (C), Satin Black and Chrome (BL/C), Black Bronze with English Brass (BBEBR).

Features: A Deco inspired collection featuring rectangular section tube which joins the circular base with a stepped detail. Shallow bespoke shades with bottom fabric diffusers and integral LED light source are supported from above and surround Opal acrylic top diffusers.

See following page for matching wall lights and table lamps.



CC/110 TL/BB/EBR with optional shade Q110 TL/HE



CC/110FS/BL/C with optional shade Q110FS/NAT

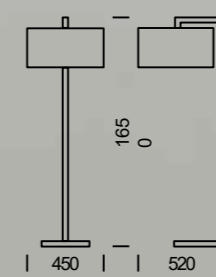

LED 12W 2700K
 CE IP20
 (For UL please enquire.)



CC/110FS/BB with optional shade Q110FS/GAB



CC/110FS/C with optional shade Q110FS/NAT



CC/110FS/BB/EBR with optional shade Q110FS/BG

Copyright 2018 Chelsom Ltd

brass for EBRfinish) with acrylic diffuser.

Features: A Deco inspired collection featuring rectangular section tube which joins the circular base or backplate with a stepped detail. Shallow bespoke shades with integral LED light source are supported from above and surround Opal acrylic top diffusers. Table lamps have colour co-ordinated push switches in the base.

Satin Black and Chrome (BL/C), Black Bronze with English Brass (BB/EBR).

pages for matching floor lamps.



Copyright 2018 Chelsom Ltd

Materials:
Steel with
acrylic diffuser.

Features: A collection of wall, desk and floor lighting featuring a double cone head with decorative slots to allow light spill. Various colour finishes are available and warm white integral LED light emits through frosted acrylic diffusers. Arm for MT/13W1A slides up and down, rotates, adjusts with locking key and the head swivels.

Finishes: Black Bronze (BB), Satin
Black with Polished Chrome (BL/C),
Ivory with Polished Chrome (IV/C).

See following
pages for matching
floor lamps.



Copyright 2018 Chelsom Ltd

Steel with acrylic diffuser.	Black with Polished Chrome (BL/C), Ivory with Polished Chrome (IV/C).	for matching desk and wall lights.
------------------------------	--------------------------------------------------------------------------	------------------------------------

Materials: Steel (with Brass for EBR finish) with acrylic diffuser.

Finishes: Black Bronze (BB), Black Bronze with English Brass (BB/EBR), Satin Black with Chrome (BL/C), Polished Chrome (C), Black Bronze with Satin Copper (BB/COP SAT), White with Gold (W/GO)— custom finishes for minimum 50 pieces.

Features: Shallow directional head with Opal acrylic diffuser houses warm integral LED light. See following pages for matching items.



MT/ 13FS/BB
| 870 |
| 325 |
LED 6W 2700K
CE IP20
(Requires modification for UL.)



MT/ 13FS3M/C
| 480 |
| 1570 |
| 280 |
3x LED 6W 2700K
CE IP20
(Requires modification for UL.)



SE/ 14/DL/BL/C
| 340 |
| 1800 |
| 175 |
LED 6W 2700K
CE IP20
(Requires modification for UL.)



SE/ 14/DL/BB/ COP SAT
(custom finish)



SE/ 14/DL/ W/ GO
(custom finish)

Copyright 2018 Chelsom Ltd

brass for EBRfinish)
with acrylic diffuser.

Finishes: Black Bronze (BB), Black Bronze with English Brass (BB/EBR), Satin Black with
Chrome (BL/C) and Polished Chrome (C), Black Bronze with Satin Copper (BB/COP SAT),
White with Gold (W/GO) and other custom finishes for minimum 50 pieces.

integral LED light. Pendants are suspended on clear cable and have colour
co-ordinated ceiling plates. Wall lamps have integral toggle switches.

page for matching
desk lamps.

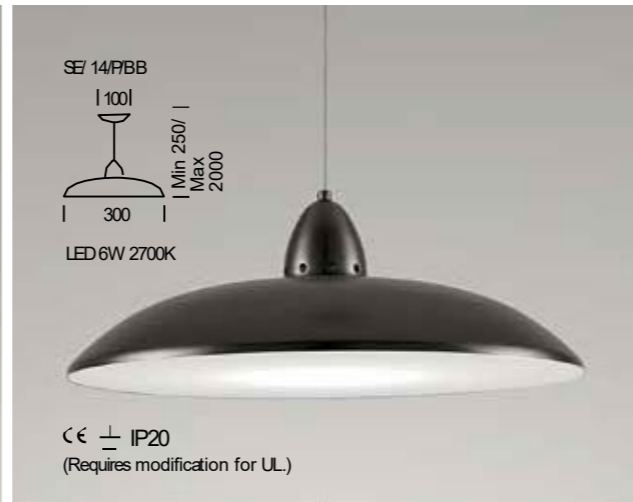

Copyright 2018 Chelsom Ltd

Materials: Steel and aluminium.
Finish: Satin Black with Aluminium accents.

Features: A range of multi-directional bedside or desk reading lights. Arm positions adjust at two separate points secured by locking keys. Heads are held in a stirrup mechanism for adjustment. Metal shades are painted White inside for extra light output. The wall light has a rocker switch on the backplate.



BC/10/FS
| 550 |
| 240 |
13
10
1x E27 7W LED 2700K
CE IP20
(For UL please enquire.)



BC/10/W1
| 140 | | 600 |
10
10
1x E27 7W LED 2700K
CE IP20
(For UL please enquire.)



BC/10/TL
| 400 |
62
160
1x E27 7W LED 2700K
CE IP20
(For UL please enquire.)

Copyright 2018 Chelsom Ltd

Materials:
Steel with
acrylic diffuser.

Finishes: Satin Black with Brushed Brass (BL/BRB) and Satin Black with Polished Chrome (BL/C). Table and wall lights have combination finishes, pendants are in single finishes. MH/2/W1/EBR is in English Brass finish to special order for minimum 50 pieces.

Features: Table and wall lights have fully directional heads moving up/down and rotating left/right. Wall light has colour co-ordinated on/off push switch and table lamp has knurled rotary dimmer switch. Cable is black silk-covered.

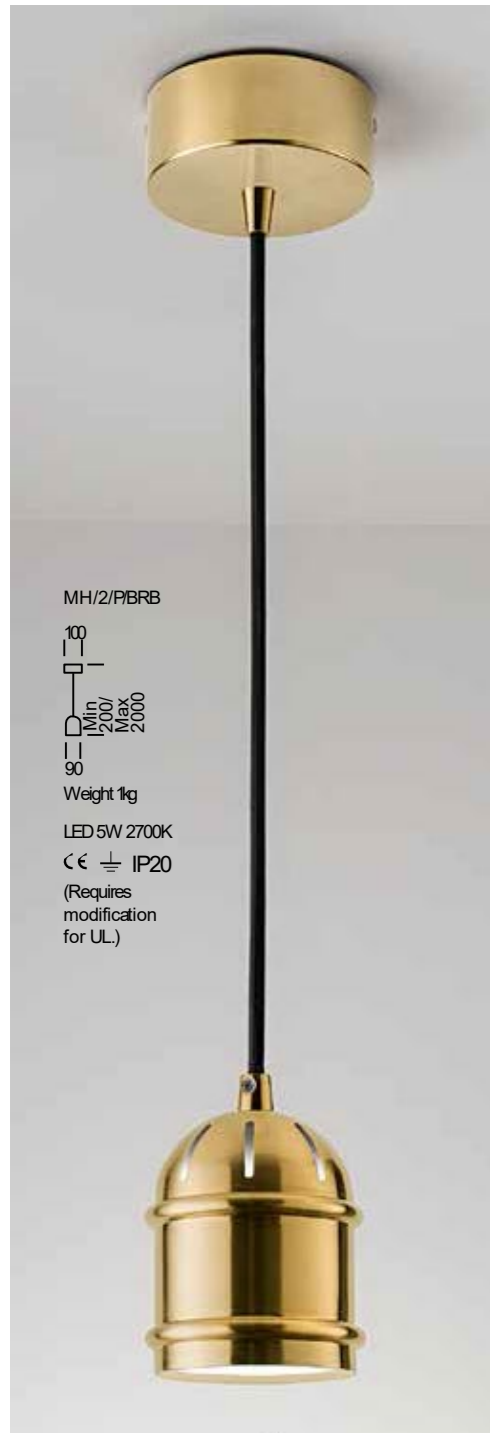

MH/2/PBRB

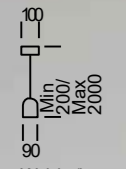

Weight 1kg
LED 5W 2700K
CE \neq IP20
(Requires modification for UL.)



MH/2/DL/BL/C

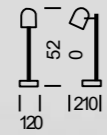

LED 5W 2700K
CE \neq IP20
(Requires modification for UL.)



MH/2/PBL



MH/2/W1/EBR (custom finish)

LED 5W 2700K
CE \neq IP20
(Requires modification for UL.)

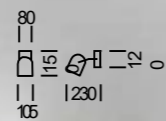

MH/2/W1/BL/BRB



MH/2/DL/BL/BRB

Copyright 2018 Chelsom Ltd

Materials:
Steel with
acrylic diffuser.

Finishes: Black
Bronze (BB) or
Polished Chrome (C).

Features: Sleek swivel arm action allows 270° rotation or shade can be 'parked' within the top framework. Shades have detailed Opal acrylic top diffuser. Neat when 'parked', the shades give a wide arc of light when extended. For floor and table, the cable exits above the slim flat bases.



FK/ 16FS/BB with optional shade QPK/ 16OY

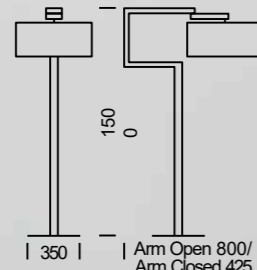

1x E27 8W LED 2700K
CE U_L IP20



FK/ 16/TL/BB with optional shade QPK/ 12OY

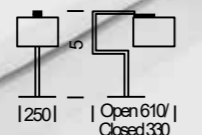

1x E27 7W LED 2700K
CE U_L IP20



FK/ 16/W1/BB with optional shade QPK/ 10 OY

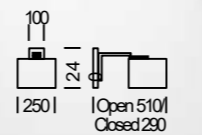

1x E27 7W LED 2700K
CE U_L IP20



FK/ 16FS/ C with optional shade QPK/ 16/W

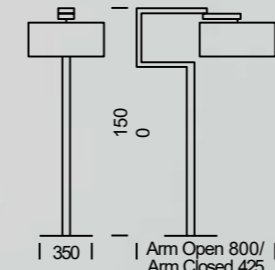

1x E27 8W LED 2700K
CE U_L IP20



FK/ 16/TL/ C with optional shade QPK/ 12/W

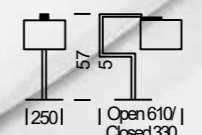

1x E27 7W LED 2700K
CE U_L IP20



FK/ 16/W1/C with optional shade QPK/ 10 W

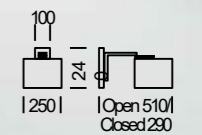

1x E27 7W LED 2700K
CE U_L IP20

Copyright 2018 Chelsom Ltd

Material:
Steel.

Finishes: Polished
Chrome (C) or
Black Bronze (BB).

Features: Robust detailed hinges allow arms
to swivel. Cylindrical heads with ventilation
hole rotate to give directional reading light.

Project: SWING READING at Six Senses Douro Valley.
Designer: Godagh Design.



SW 40/FS/BB

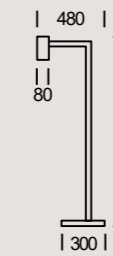

1x GU10 7W LED 2700K
CE U L IP20



SW 40/W1/C

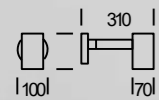

1x GU10 7W LED 2700K
CE U L IP20



SW 40/W1/BB

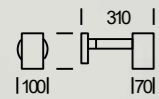

1x GU10 7W LED 2700K
CE U L IP20



SW 40/TL/BB

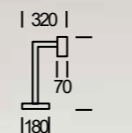

1x GU10 7W LED 2700K
CE U L IP20



SW 40/TL/C

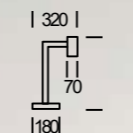

1x GU10 7W LED 2700K
CE U L IP20



SW 40/FS/C

Material:
Steel

Finishes: Antique
Brass (AB) or
Polished Chrome (C).

Features: Robust
detailed hinges allow
arms to swivel.

Shades: See back of
catalogue for full range
of optional shades.

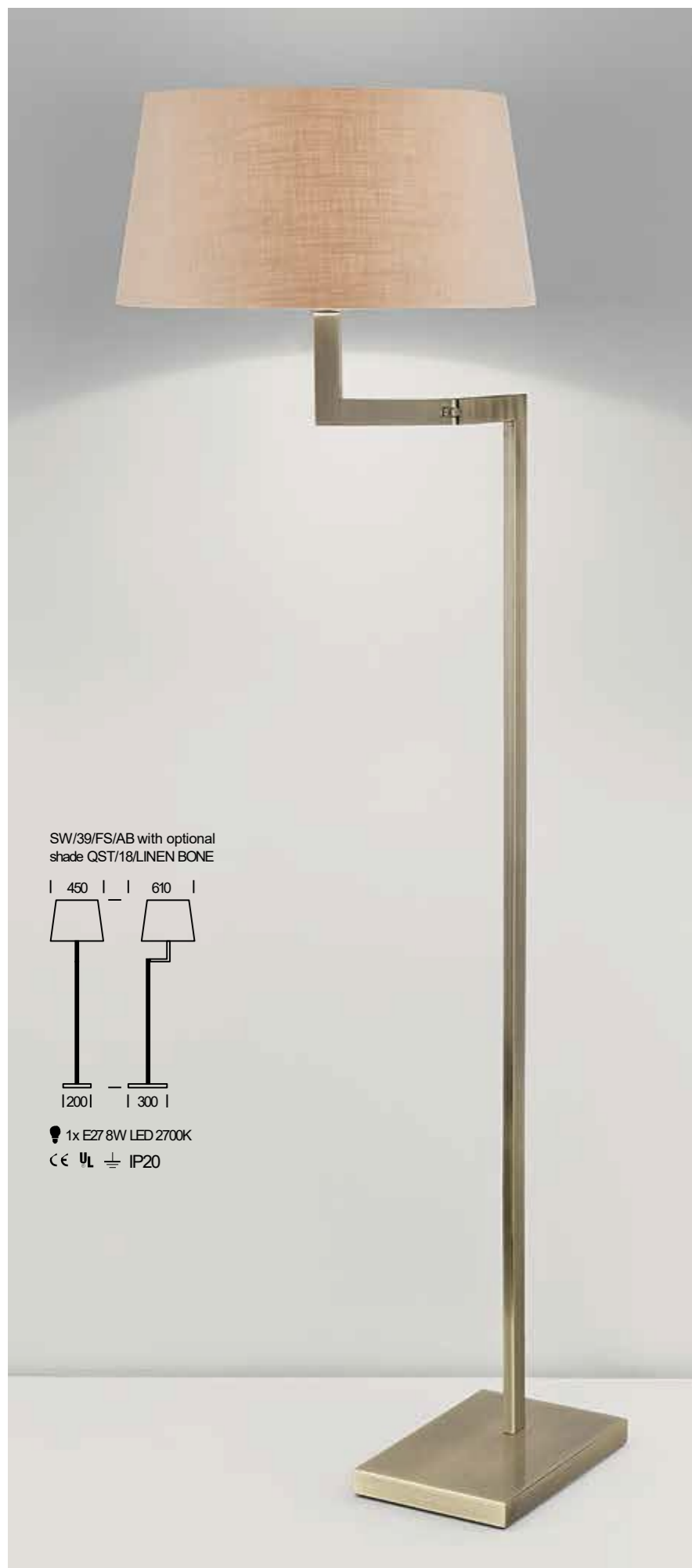

SW/39/TL/AB with optional
shade QST/12/LINEN NAT

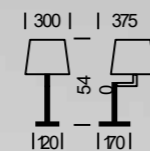

1x E27 7W LED 2700K
CE UL IP20



SW/39/W1/AB with optional
shade QFD/8/LINEN NAT

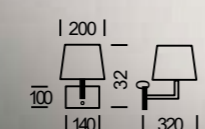

1x E27 7W LED 2700K
CE UL IP20

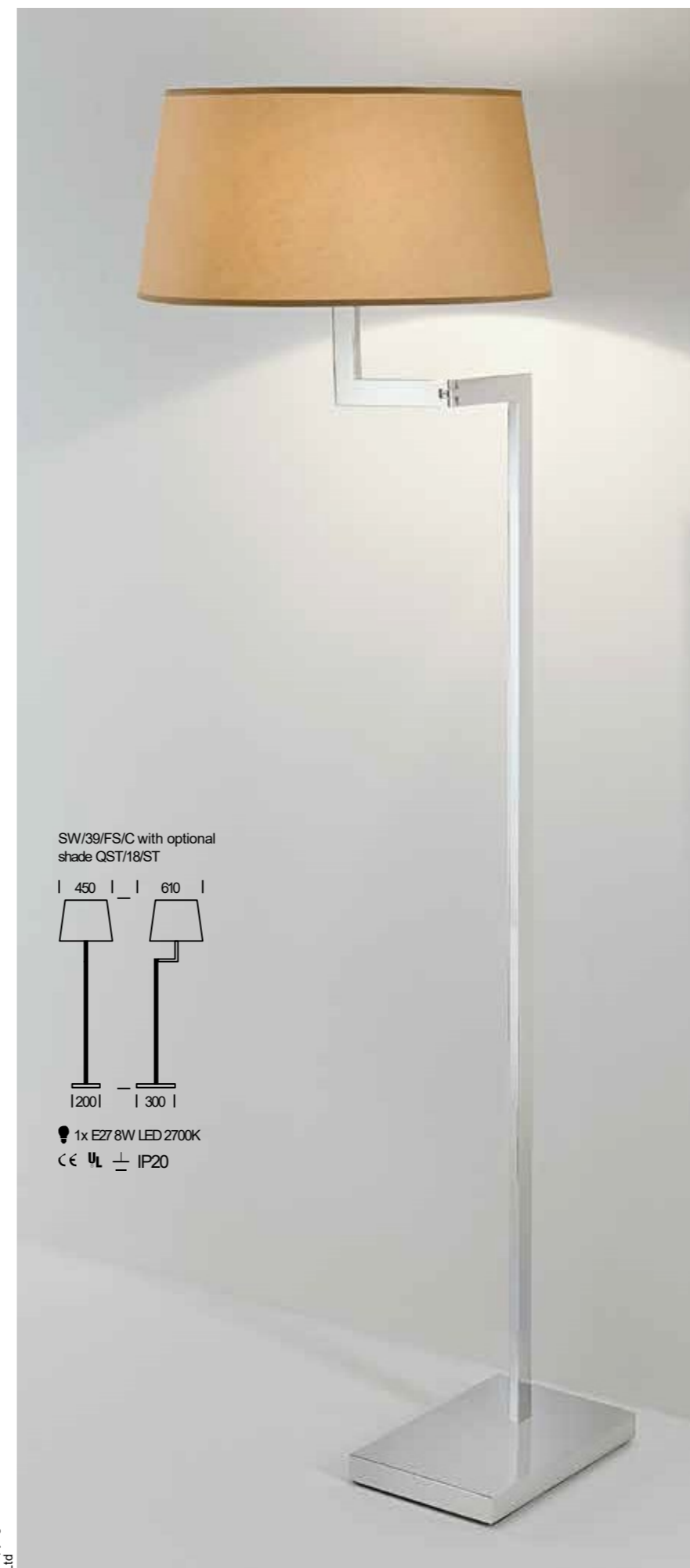

SW/39/TL/C with optional
shade QST/12/ST

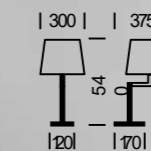

1x E27 7W LED 2700K
CE UL IP20



SW/39/W1/C with
optional shade QFD/8/ST

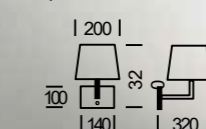

1x E27 7W LED 2700K
CE UL IP20

SW/39/FS/AB with optional
shade QST/18/LINEN BONE

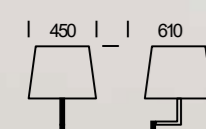

1x E27 8W LED 2700K
CE UL IP20

SW/39/FS/C with optional
shade QST/18/ST



1x E27 8W LED 2700K
CE UL IP20

Materials:
Steel (with
brass for EBR)

Finishes: Black Bronze with
English Brass (BB/EBR) or
Polished Nickel (PN).

Features: Stepped bases, deeply grooved directional handles and decorative key toothed locking joints are key features of this collection. Arms rotate at the column step, adjust up and down and the canopy heads swivel left/right. Shade interiors are White painted for extra illumination.



BI/22/RL/PN
| 900 |
| 140 |
| 300 |
1x E27 7W LED 2700K
CE U L IP20



BI/22/RL/BB/EBR



BI/22/DL/PN
| 650 |
| 70 |
| 200 |
1x E27 7W LED 2700K
CE U L IP20



BI/22/DL/BB/EBR

Copyright 2018 Chelsom Ltd

Material: Steel.
 Finishes: English Brass (EBR) or Black Bronze (BB).

Features: Rectangular stepped bases and tubular columns with triangular canopies give a timeless style. Upright columns swivel left right and the canopies rotate to give a full range of directional light. Desk lamps have knurled rotary dimmer switches and floor lamps have dimming foot switches. Canopies have internal polished metal reflectors for increased light output.

TO/10/FS/BB

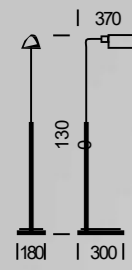

1x E144W LED 2700K
 CE UL IP20



TO/10/TL/BB

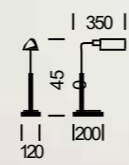

1x E144W LED 2700K
 CE UL IP20

TO/10/FS/EBR

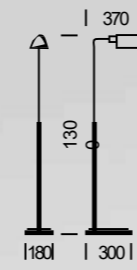

1x E144W LED 2700K
 CE UL IP20



TO/10/TL/EBR

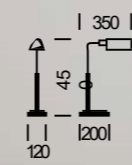

1x E144W LED 2700K
 CE UL IP20

Material: Steel.

Finishes: Black Bronze (BB), Brushed Brass (BRB) or Polished Chrome (C).

Features: Arm rotates left/right and is adjustable for height and reach with two decorative locking key swivel joints. The light source is housed in a ventilated metal shade. There is an integral knurled rotary dimmer switch in the centre of the backplate.

BA/ 5/ W1/BB

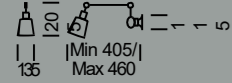

1x E27 3.5W LED 2700K
CE U_L IP20



BA/ 5/ W1/BRB



BA/5/W1C



Materials: Steel and wood.

Finish: Black Bronze (BB) with walnut wood.

Features: Decorative wooden handle allows rotational movement left and right and there is also a swivel joint above the shade. Shade options include colour matched ventilated metal or fabric – Silk Thimble shown here with other options at back of catalogue. Suitable for bedside or desk use.

DR/ 8/ W1/BB with optional shade QDR/ M/BB

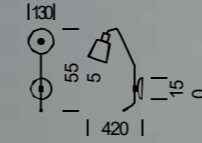

1x E27 3.5W LED 2700K
CE U_L IP20



DR/ 8/ W1/BB with optional shade QDR/ 8/ SILK THIMBLE

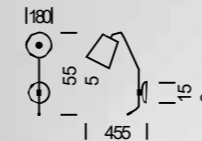

1x E27 7W LED 2700K
CE U_L IP20

Copyright 2018 Chelsom Ltd

Materials: Steel with prismatic acrylic diffuser.

Features: A sleek, semi-recessed LED bedside reading light with a push switch operated mechanism which causes the central housing to revolve and softly dock in the open position. The light which emits through a prismatic focusing lens comes on automatically. To close, there is a dimple within the housing to rotate the unit back into the off/closed position. See overleaf for installation details.

LED 6/BN



Image shown at actual size.

The product is mounted with the switch nearest to the bed.

Push switch to operate.



Central housing revolves and illuminates.



Focused directional reading light.



Easy-push dimple to close and switch off.



Image shown at actual size.

The LED warm white light focuses toward the reading position.

Finishes: Brushed Nickel front plate and housing (BN); Satin Black front plate with Brushed Nickel housing (BL/BN); Polished Chrome front plate with Brushed Nickel housing (C/BN); Black Bronze front plate and housing (BB); Brushed Brass front plate with Satin Black housing (BRB/BL).

Project: LED REVOLUTION at Yokohama Bay Sheraton Hotel and Towers, Japan. Designer: Naoko Horii Design Concepts.



LED 6/BB

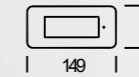

LED 1W 2700K
CE UL IP20



LED 6/BL/BN



LED 6/BB



LED 6/C/BN



LED 6/BRB/BL



LED REVOLUTION

LED Revolution is for headboard or cavity wall installation and cutout sizes and fixing details are shown below. The design allows left or right mounting governed by the orientation of the switch. Once the unit is secure, the front plate simply snaps into position and is easily removed for maintenance by inserting a small screwdriver into the rebate on one corner.

Removing front plate from snap-on mechanism



Product is to be mounted horizontally and cutout dimensions must be 115mm x 62mm.

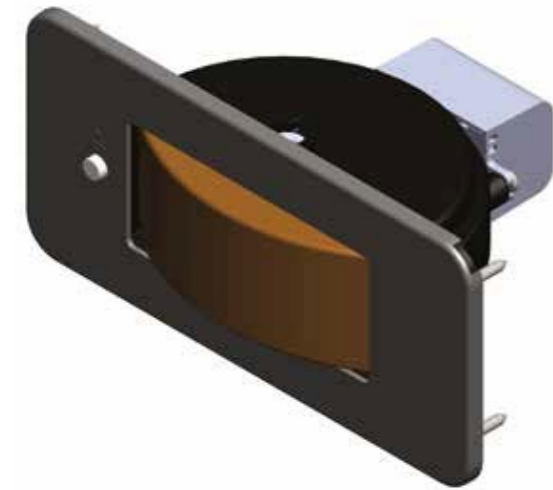

Driver integrally mounted

The inner housing assembly is screwed to the headboard with the driver normally mounted on the back.

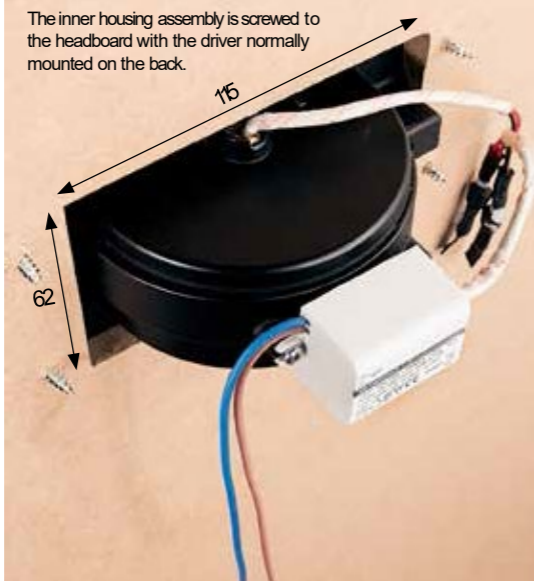

Driver remotely mounted

If there is insufficient depth behind the headboard the driver can be sited remotely.

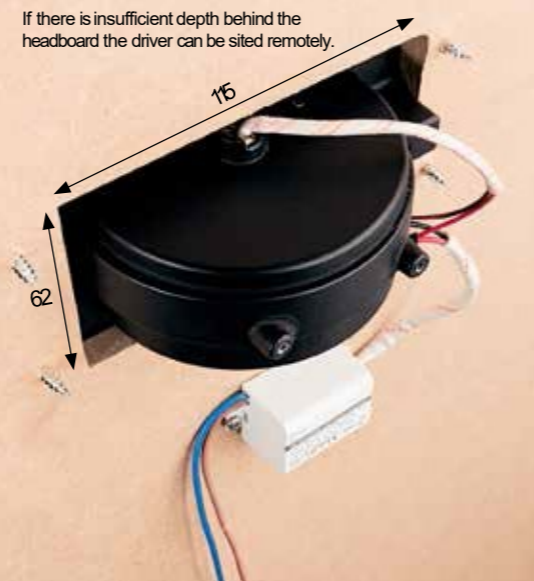

Elevation

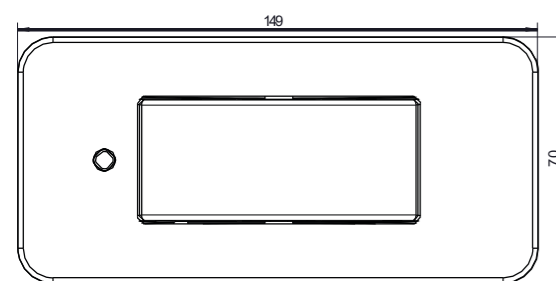

Plan - Driver Integral

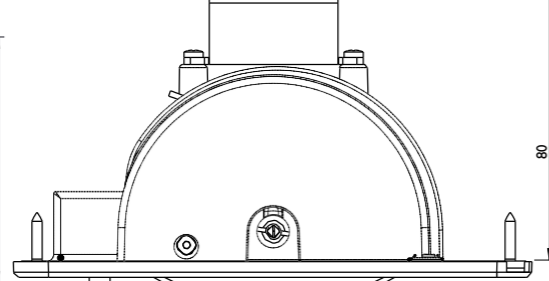

Plan - Driver Remote

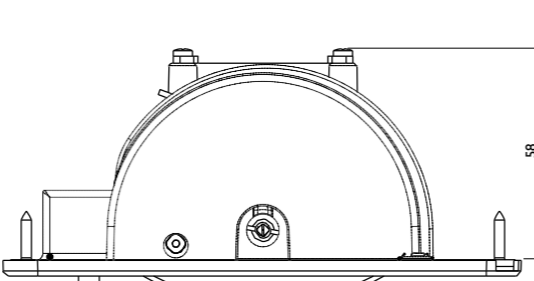

Materials:
Steel (with brass for EBR finish).

Finishes: Polished Chrome (C), Black Bronze (BB), Black Bronze with English Brass (BB/EBR), Satin Black with Chrome (BL/C), Brushed Nickel (BN) and English Brass (EBR).

Features: Finish options for this range of headboard reading lights are shown below with other design and switching options, plus installation information on the following pages.

LED DOCK

Project: LED DOCK at A Bode Glasgow.
Designer: 10 Design.

LED/5/1/BB/EBR
LED 1W 2700K
CE UL IP20



LED/5/1/C



LED/5/1/BN



LED/5/1/BL/C



LED/5/1/BB



Copyright 2018 Chelsom Ltd

Materials:
See page 99.

Finishes:
See page 99.

Features: A warm white LED reading light is housed within a cylindrical or rectangular head that swivels 90° left, right or forward and 'docks' into a semi recessed backplate, which can be vertically or horizontally mounted. Docking switch or push switch options are available (see page 103).



Copyright 2018 Chelsom Ltd

Materials:
See page 99.

Finishes:
See page 99.

Features: See page 99. The Dock range can be offered to special order with an integral USB port fitted for minimum 50 pieces. Note: LED driver is integral but USB transformer is remote – see diagram below. For headboard mounting only.

Switching options: Available with automatic docking switch in the backplate recess, or with shallow push switch in the base of the backplate (except USB version).

Installation: For simple installation, headboards can be prepared incorporating cutouts and fixing holes as shown in the templates below. Units come complete with switch, LED driver and terminal block fitted to the back for ease of electrical installation. Once connections are made the internal backplate is screwed to the headboard recess and finally the front cover plate is fitted with one discrete locating screw at the bottom.

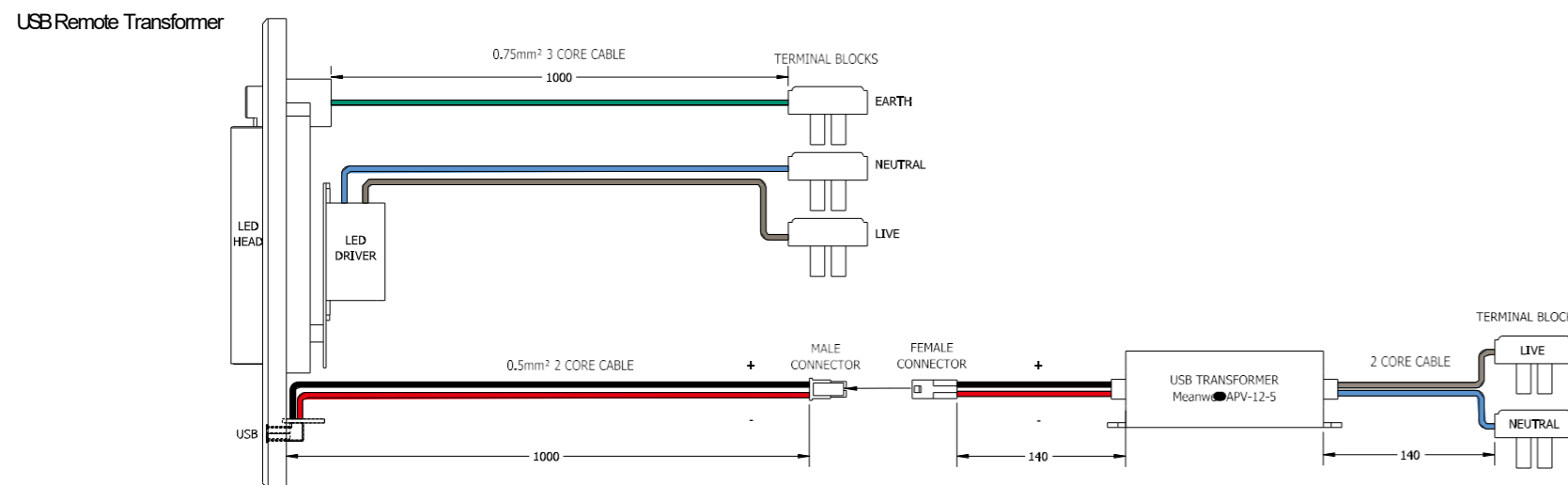
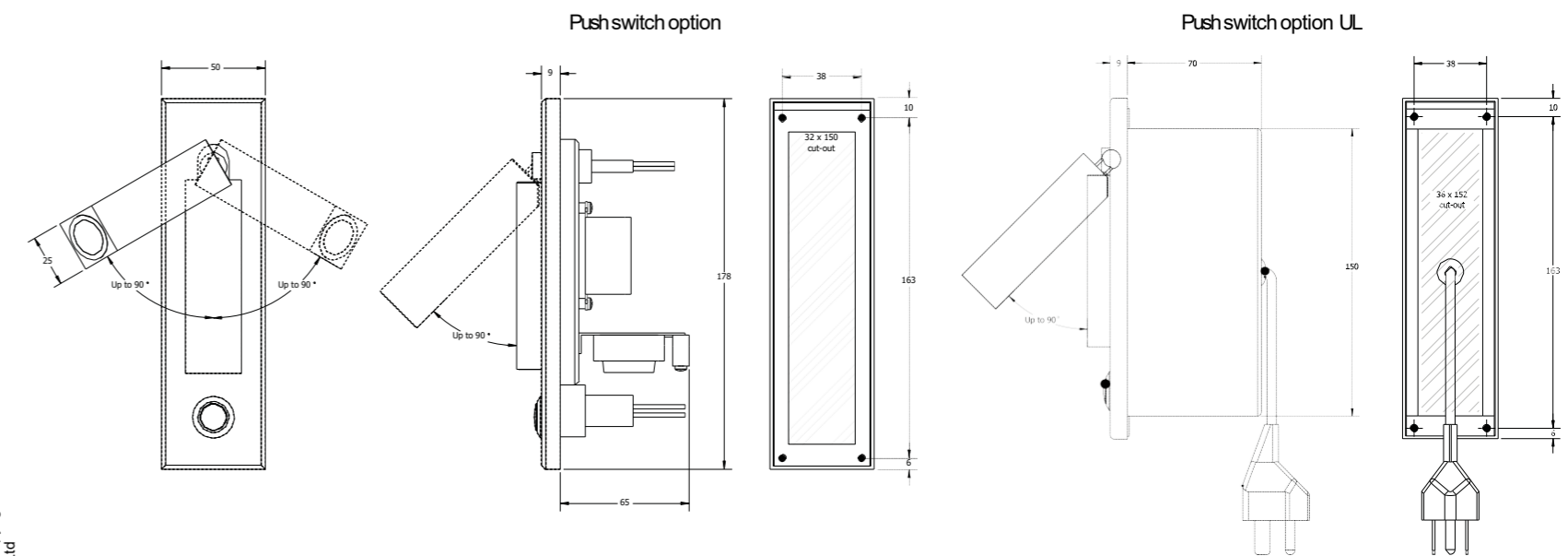
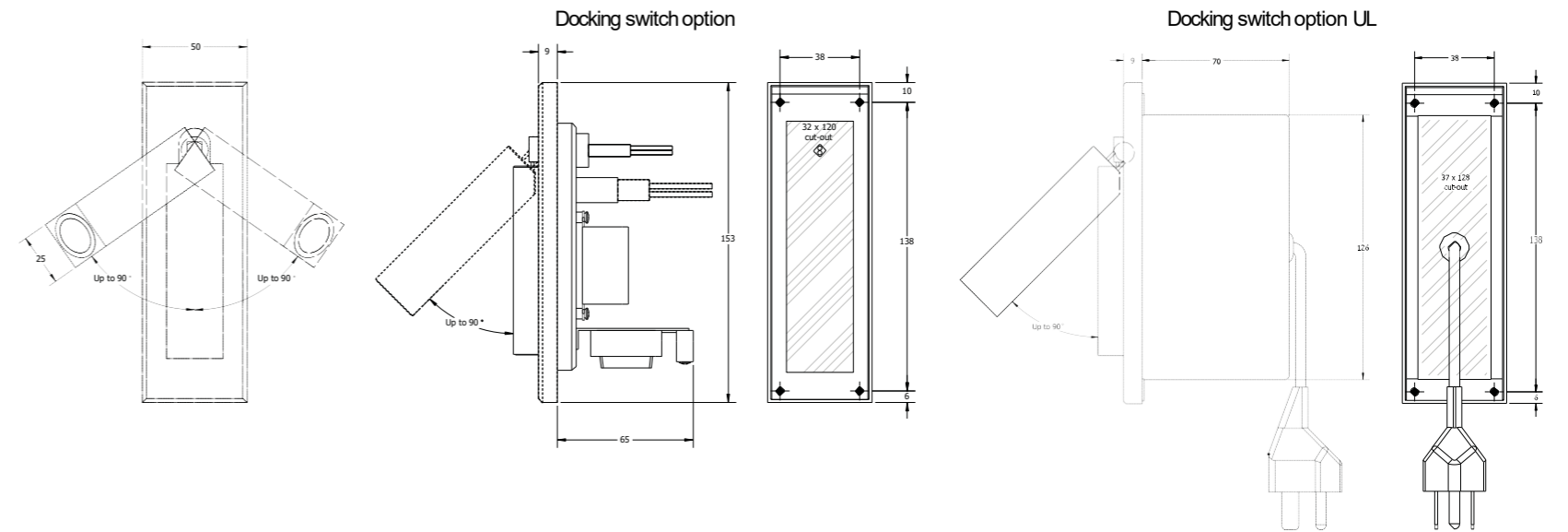

Copyright 2018 Chelsom Ltd

Material: Steel.

Finishes: Black Bronze (BB) or Polished Chrome (C).

Features: Slender guestroom or cabin bedside wall lights with main room illumination from within the fabric shade, an LED reading light and a USB charging port. The reading light has a docking switch, the main light a push switch. The USB port remains powered even when lights are switched off.

Material: Steel.

Finishes: Polished Chrome (C), Brushed Nickel (BN), Aluminium (AL) and Black Bronze with English Brass (BB/EBR).

Features: Backplate houses colour co-ordinated push switch. Integral driver is in the arm. Arm swings left – right and head rotates for good light distribution.



Copyright 2018 Chelsom Ltd

Material: Steel.
 Finishes: Black Bronze (BB),
 Brushed Nickel (BN) and
 Brushed Brass (BRB).

Features: The cylindrical heads have detailed knurling and a black on/off push switch. All three finishes are available with rectangular backbox housing an integral driver or with discrete round backplate with concealed fixings for remote driver location. Prices include integral or remote driver. An option with integral USB port and remote transformer is available for minimum quantity 50 pieces and for headboard mounting only.

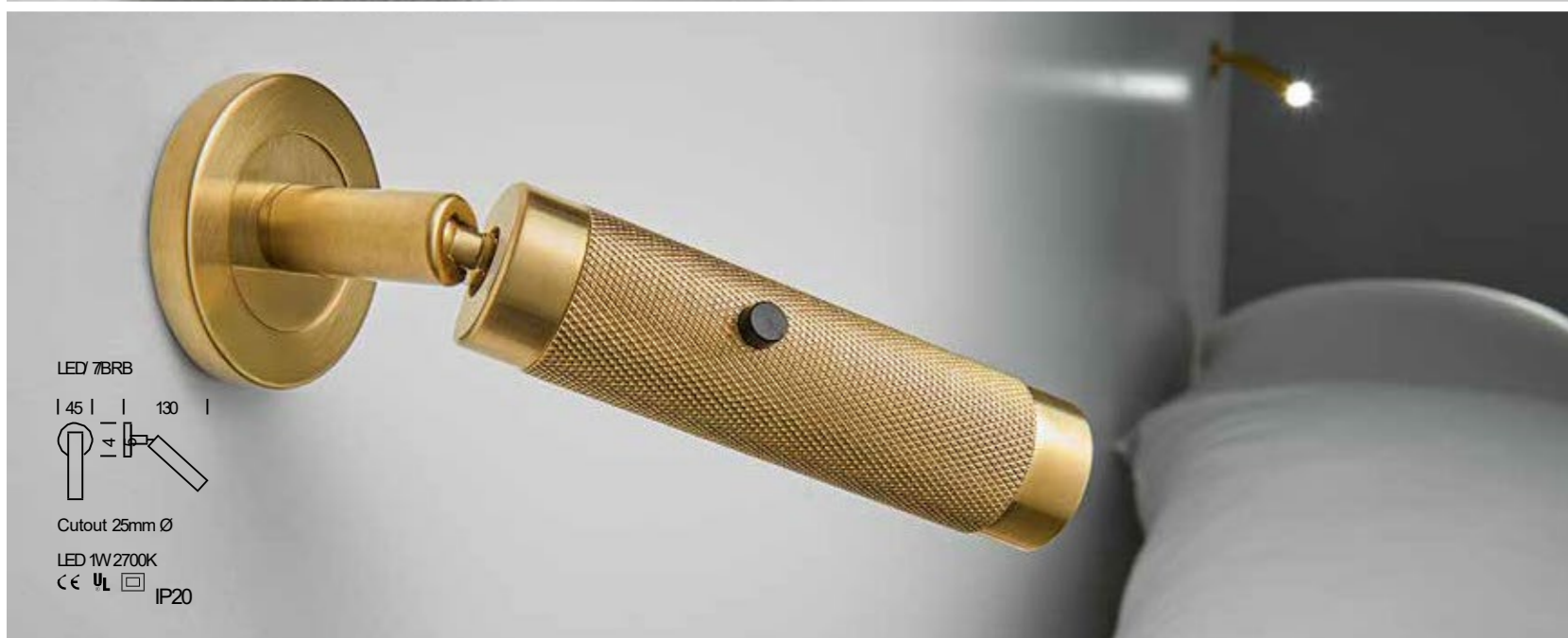
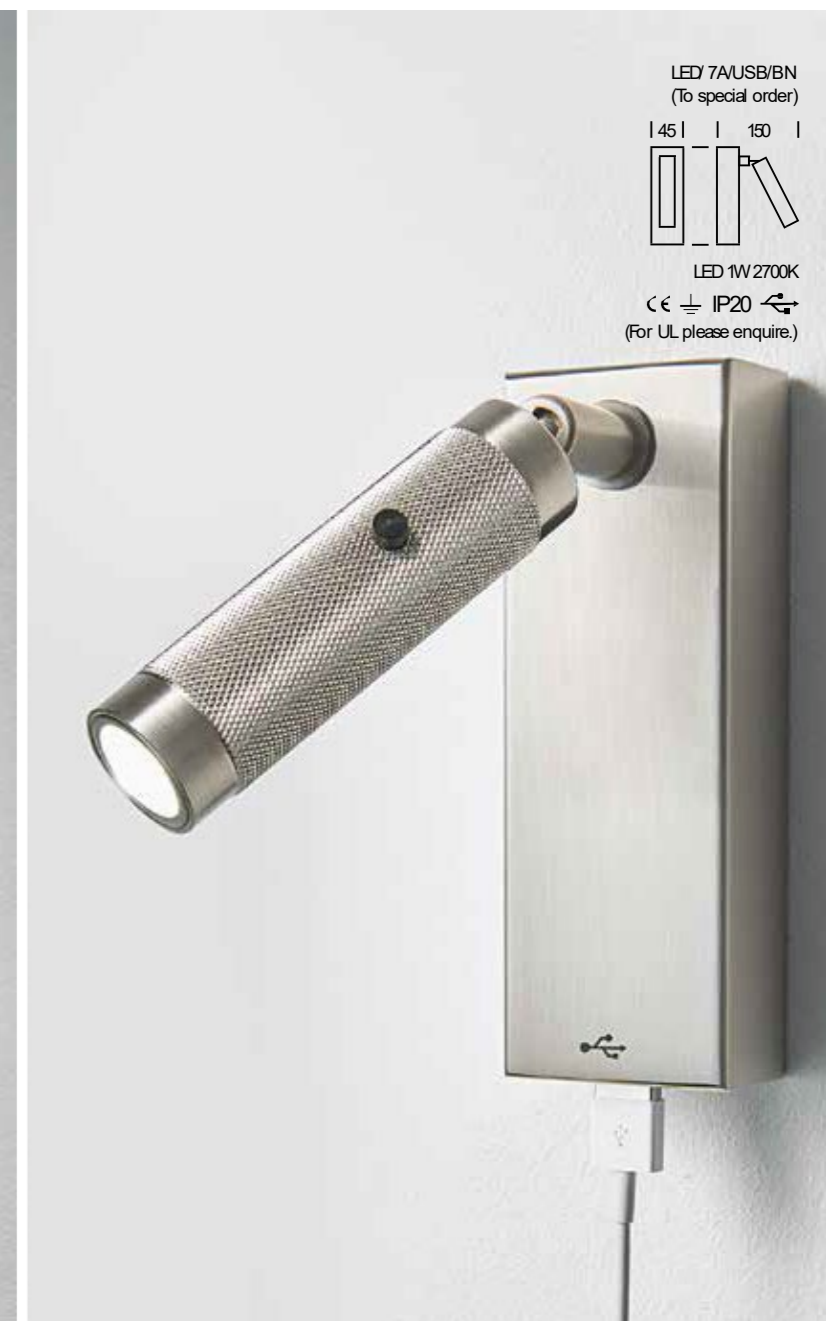

Copyright 2018 Chelsom Ltd

LED GROOVE

Material: Steel.
 Finishes: Polished Chrome (C), Black Bronze (BB), Brushed Brass (BRB) and Brushed Nickel (BN).

Features: Inspired by last century stage lighting, the LED heads have a deeply grooved double line. The heads give a full range of directional adjustment and different backplates allow switching remotely or by an integral push switch. Prices include remote driver.

LED 9/SWC
 | 62 || 15 |

 Cutout 35mm Ø
 LED 1W 2700K
 CE U L IP20



LED CLASSIC

Material: Steel.
 Finishes: English Brass (EBR), Black Bronze (BB), Brushed Nickel (BN) and Polished Chrome (C).

Features: For the more traditional interior, LED Classic features a detailed backplate with integral toggle switch and a sculptured head secured by knurled rings on a stirrup bracket. Prices include remote driver.

LED 8/EBR
 | 65 || 95 |

 Cutout 35mm Ø
 LED 1W 2700K
 CE U L IP20

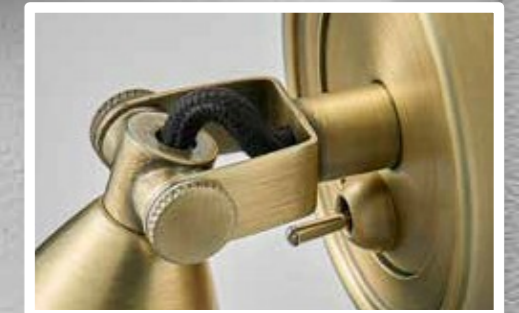



Material: Steel.
 Finishes: Black Bronze (BB), Brushed Nickel (BN), Brushed Brass (BRB), Satin Black (BL) and Polished Chrome (C).

Features: The cylindrical heads have a black on/off push switch. Rectangular backbox houses an integral driver or discrete round backplate has concealed fixings for remote driver. Prices include integral or remote driver. An option with integral USB port and remote transformer is available for minimum quantity 50 pieces and for headboard mounting only. Combination wall lights are for double or twin bed configurations with main light switched remotely (integral switching to special order for minimum 50 pieces).



LED 10 C

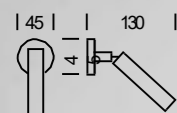

Cutout 25mm Ø

LED 1W 2700K
 CE U_L IP20



LED 10A/BB

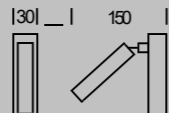

LED 1W 2700K
 CE U_L IP20



LED 10BL



LED 10BRB



LED 10A/USB/BN
 (To special order.)

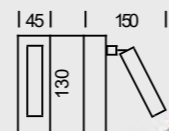

LED 1W 2700K
 CE U_L IP20
 (For UL please enquire.)



LED 10' W1/BN with optional shade QL10' GM

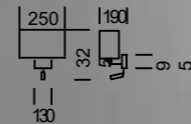

1x E27 7W LED 2700K
 plus 1x LED 1W 2700K
 CE U_L IP20



LED 10' W2/C with optional shade QL10' OY

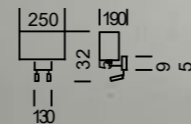

2x E27 7W LED 2700K
 plus 2x LED 1W 2700K
 CE U_L IP20



Copyright 2018 Chelsom Ltd



Material: Steel.
 Finishes: Brushed Nickel (BN), Brushed Brass (BRB), Satin Black (BL), Polished Chrome (C) and Aluminium (AL).

Features: A collection of reading lights with either grooved cylindrical heads or tapered designs and high quality focussing lenses. Backplates are for integral or remote switching. Prices include integral or remote driver. Note: Flexi arms are robust 10mm diameter.



LED/750/BRB
 | 62 | | 65 |
 Cutout 35mm Ø
 LED 1W 2700K
 CE U_L IP20



LED/418/SWAL
 | 62 | | 100 |
 Cutout 35mm Ø
 LED 1W 2700K
 CE U_L IP20



LED/100/BN
 | 235 |
 Cutout 10mm Ø
 LED 1W 2700K
 CE U_L IP20



LED/350/BN (Also available with toggle switch as LED/300* - minimum quantity 50 pieces)
 | 235 |
 Cutout 35mm Ø
 LED 1W 2700K
 CE U_L IP20



LED/500/C
 | 265 |
 LED 1W 2700K
 CE U_L IP20



LED/800/C with optional shade QOB/12/W
 1x E27 7W LED 2700K plus 1x LED 1W 2700K
 CE U_L IP20

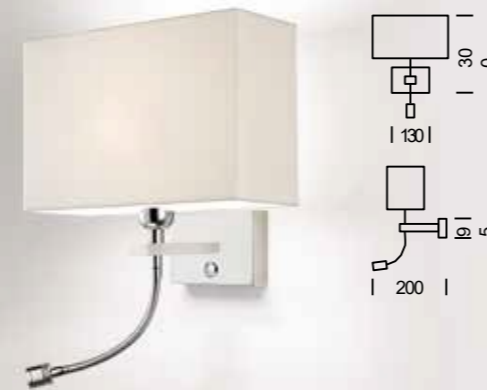

LED/418/BL
 | 35 | | 100 |
 Cutout 10mm Ø
 LED 1W 2700K
 CE U_L IP20



Project: LED READING at Sheraton Grand London Park Lane.
 Designer: MKV Design.



LED/418/SW/C

Copyright 2018 Chelsom Ltd

Materials: Steel and stone. Finish: English Brass (EBR) with natural stone.

Features: DL/19EBR includes adjustable metal shade and its arm rotates and moves up and down held by a knurled locking key. External fabric-covered cable is cord-gripped and passes through a retaining ring near the base. SW/40/TL/EBR/STONE has a robust detailed hinge allowing the arm to swivel. The cylindrical head with ventilation hole rotates to give directional reading light.



Copyright 2018 Chelsom Ltd

Materials:
Steel and
optional stone.

Finishes: Black Bronze with English Brass (BB/EBR) or Polished
Chrome (C). Black Bronze with Stone (BB/STONE), White with
Gold (W/GO) and other custom finishes for minimum 50 pieces.

Features: Desk lamp has an integral LED light source and a
colour co-ordinated push switch in base (except custom
Stone option). Opal acrylic diffuser gives good diffused light.



Copyright 2018 Chelsom Ltd

DESK STUDY

Steel.

Brass (BB/EBR), Polished Chrome (C),
Black Bronze (BB), English Brass (EBR).

toothed locking key swivel joints. Bases include integral toggle switch. Other shade fabric options are available to special order.

DL/ 12/C with optional shade Q12/BL



DL/ 12/BB with optional shade Q12/OY



DL/ 12/BB/EBR with optional shade Q12/OY

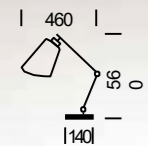

1x E27 7W LED 2700K
UL IP20

DL/ 12/EBR with optional shade Q12/MPL



Copyright 2018 Chelsom Ltd

Project: STUDY at Mandarin Oriental Hyde Park, London.
Designer: Joyce Wang Studio.

DESK CANOPY

Material:
Steel.

Finishes: Black Bronze with English Brass (BB/EBR), Satin Black with Chrome (BL/C).

Features: Adjustable canopy gives good light direction with internal reflector plate. Colour co-ordinated push switch in base.

Steel with acrylic diffuser.

Polished Chrome and other finishes available to special order for minimum quantities.

slim arm. Desk lamp arm swivels 90° left and right – floor lamp arm is fixed. Desk lamp has colour co-ordinated push switch in the base.



Copyright 2018 Chelsom Ltd

Steel.

Nickel (BN) or
Soft White (SW).

reading light. Wall light head also rotates to give a full range of directional light.
Desk and wall models include colour co-ordinated push switch and integral driver.

remote) transformer. Modifications to depth of table lamp base or wall light backplate may be required in order to house the port and transformer. Charging ports are always wired on a separate circuit to ensure charging continues whether the lamp is remotely switched on or off. A minimum of 50 pieces is required for production. See overleaf for further examples.

CHARGING

DL/28/BN

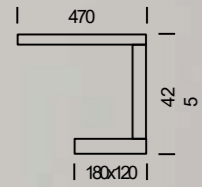

LED 8W 2700K
CE IP20
(For UL please enquire.)



WL/28/SW



DL/28/SW



LED/5/1/USB/C
See page 102



Copyright 2018 Chelsom Ltd

Shown are examples of standard catalogue items with modifications to include USB charging ports. See previous page for more detail. A minimum of 50 pieces is required for production.

CR/ 7DL/USB/C
See page 121



DL/ 4/USB/C
See page 120



LED/ 5/ 1/USB/C
See page 102



LED/ 7A/USB/BN
See page 107

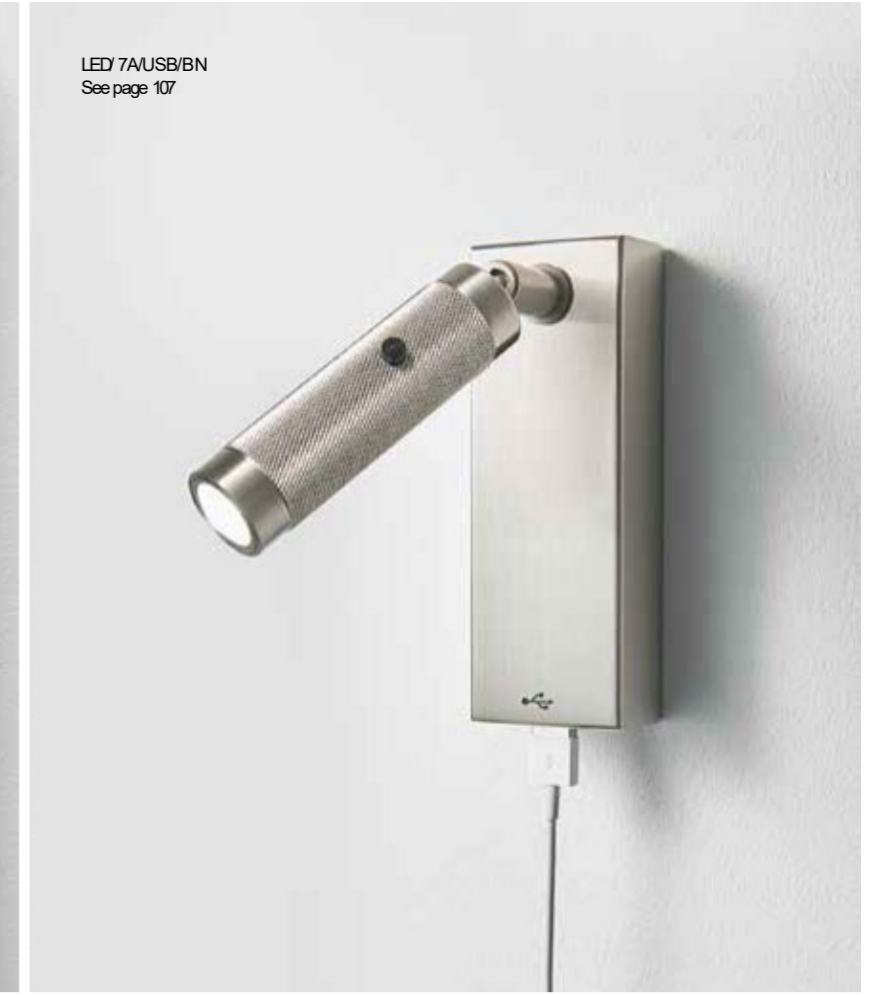

PJ/9/ TL/USB/C with
optional shade QRTS/ 12/W
See page 156



DL/ 28/USB/C
See page 122



LED/ 10A/USB/BN
See page 110



LED/ 5/ 2/W1/USB/BB
See page 104



Copyright 2018 Chelsom Ltd

TRAVELLER

Materials: Steel with acrylic top diffuser. Finishes: Black Bronze (BB) or Polished Chrome (C).

Features: A double square section tube detail suspends the fabric shade which has an Opal acrylic top diffuser. Table and wall lights have a USB charging port as standard and the wall bracket includes an LED reading light operated by a colour matched push switch and an integral driver.



TV 36/TL/C with optional shade QTV TL/OY
 1x E27 7W LED 2700K
 CE IP20
 (For UL please enquire.)

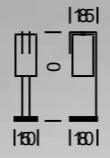

TV 36/W1LEDBB with optional shade QTV W1/OY
 1x E27 7W LED 2700K plus 1x LED 1W 2700K
 CE IP20
 (For UL please enquire.)

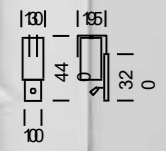

Materials: Steel and wood.

Finish: Golden Bronze with Ebony.

Features: Chunky Ebony stained wooden sections combine with reeded tubing to feature in this elegant guestroom lighting design.

PIAZZA



PI/38/W1 with optional shade QCY 7 TALL/NAT
 1x E27 7W LED 2700K
 CE UL IP20

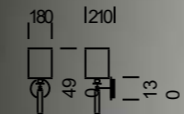

Copyright 2018 Chelsom Ltd

PI/38/TL with optional shade QCY 14/NAT
 1x E27 7W LED 2700K
 CE UL IP20



PI/38/FS with optional shade QCY 20/NAT
 1x E27 8W LED 2700K
 CE UL IP20

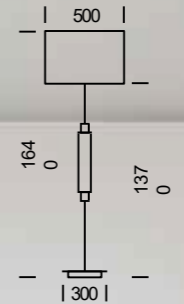

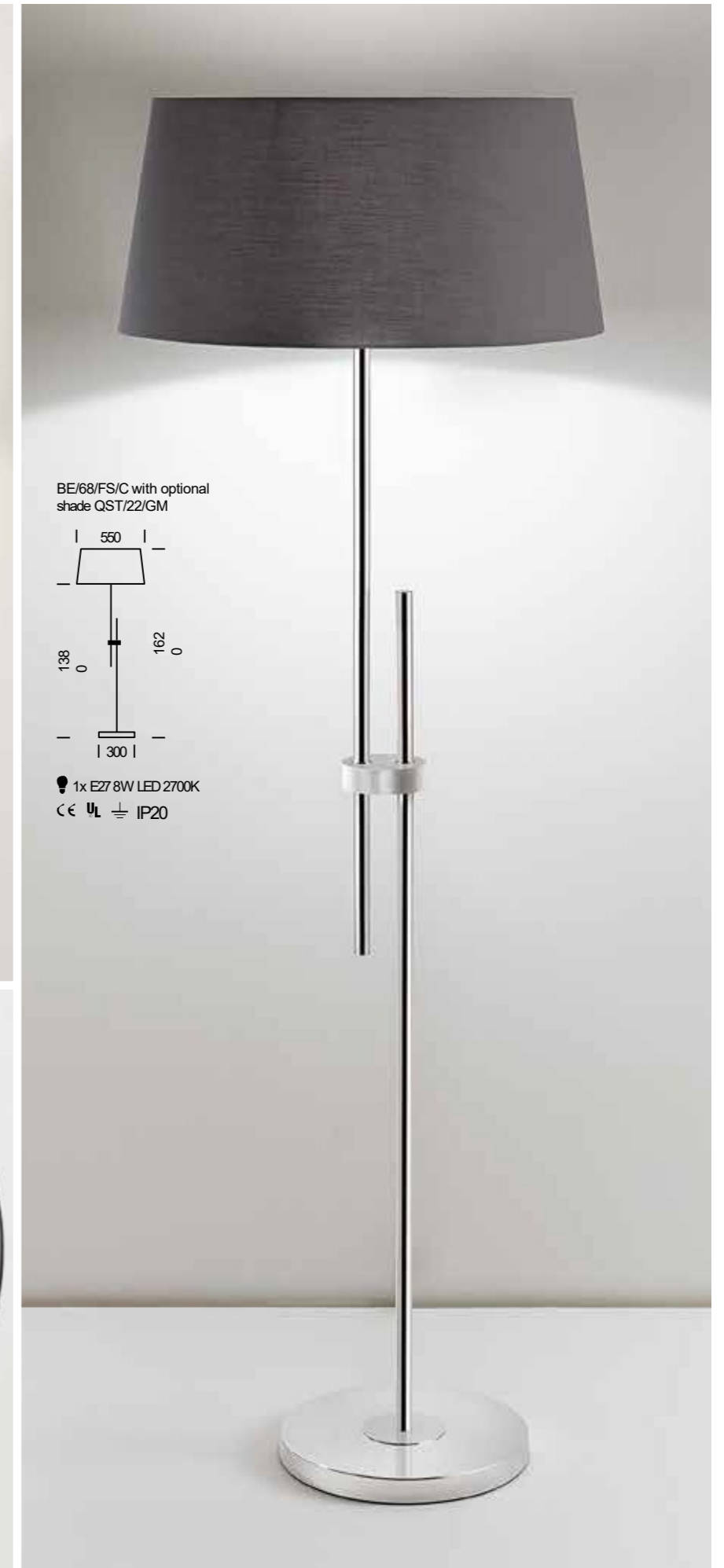

Copyright 2018 Chelsom Ltd

Material:
Steel.

Finish: Polished
Chrome with
Black underbase.

Shades: All shades are bespoke for the Check In range. Fabrics shown are Oyster cottonette (OY) and Natural (NAT). Other fabrics to special order. Shades have integral top diffusers with a central ventilation hole.



CH/9/ TL/C with optional shade QCHE/ 14/NAT



CH/9/FS/ C with optional shade QCHE/ 18/NAT

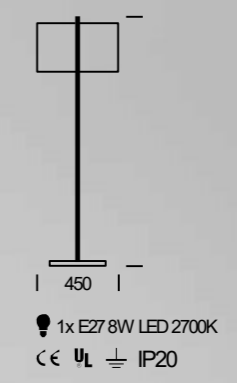

CH/9/ W1/LED/C with optional shade QCHE/ 14/OY

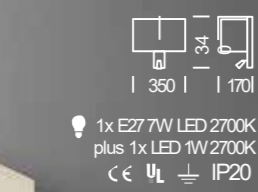

CH/9/ W1/C with optional shade QCHE/ 14/NAT

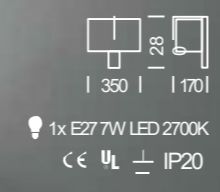

CH/9/ TL/C with optional shade QCHE/ 14/NAT

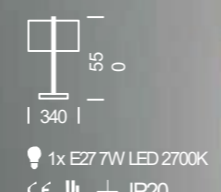

Copyright 2018 Chelsom Ltd

Material:
Steel.

Finish:
Textured
Black.

Features: Linear steel frames encase cylinder shades in a variety of fabrics. Pendant normally supplied with clear cable suspension. Fixed rod suspension for bedside use as shown to special order.

Shades: Diffusers are fitted in the top of table and floor lamp shades and bottom of pendant shade. Other fabrics available to special order.



Materials:
Steel and
wood.

Finish: Polished
Chrome with
Chocolate wood bases.

Features: Crossover sections pass one in
front of the other and wooden bases are
mounted on protective Chrome plinths.

Shades: See back of
catalogue for full range
of optional shades.

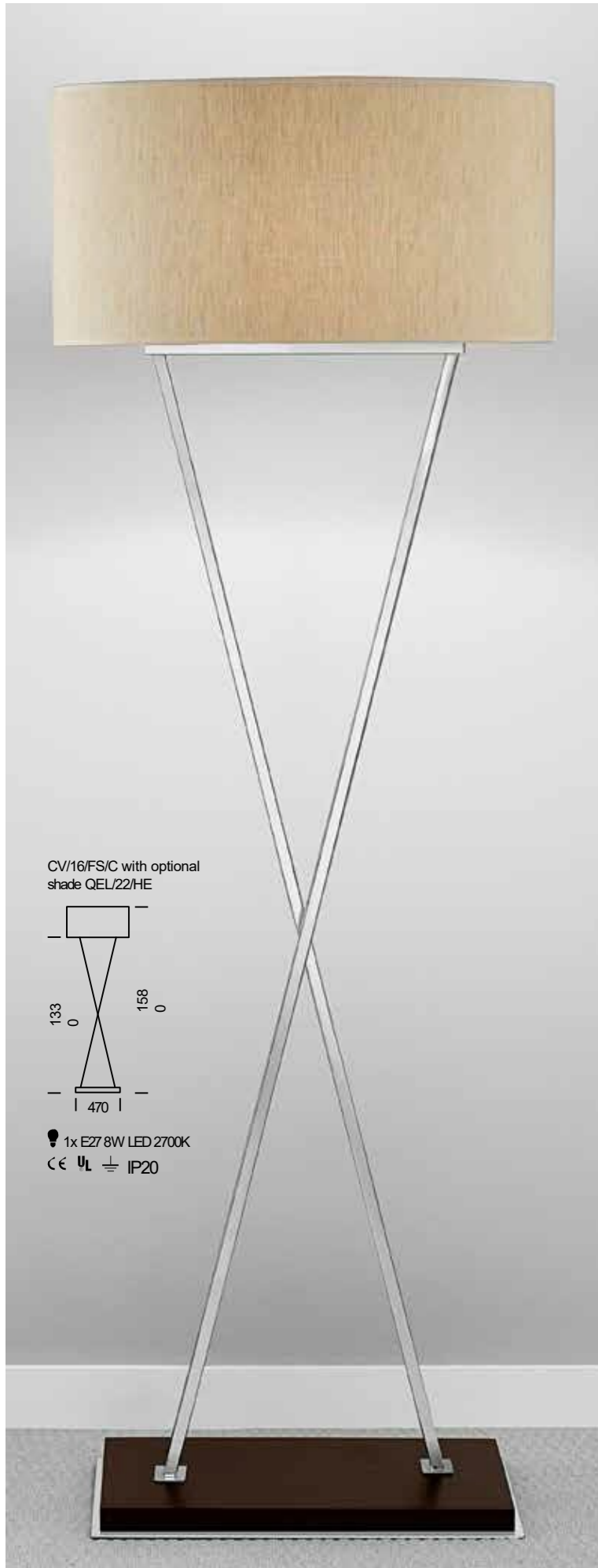

Copyright 2018 Chelsom
Ltd

Steel.

Bronze (BB) or
Polished Chrome (C).

upright angled column. All bases have securely inset rubber feet. Tall fabric cone shades give diffused light – see back of catalogue for further fabric options.

SR 15FS/BB with optional shade QSR 10/LINEN BONE

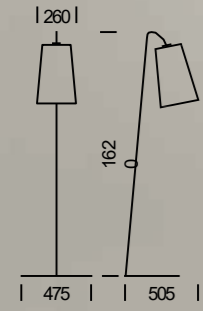

1x E27 8W LED 2700K
CE UL IP20

SR 15FS/C with optional shade QSR 10/SILK THIMBLE



SR 15 TL/BB with optional shade QSR 6/LINEN BONE

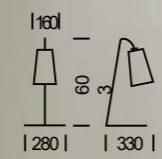

1x E27 7W LED 2700K
CE UL IP20



SR 15 TL/C with optional shade QSR 6/NAT



Material: Steel.
 Finishes: Polished Chrome (C), Black Bronze (BB) to special order for minimum quantities.

Features: Oval hollow bases and tapered columns. Desk and table lamps have colour co-ordinated push switches in base. Floor lamps have vertical (FS1) or angled (FS2) columns.

Shades: All shades are bespoke for the Exec range. Desk and table lamps have a top diffuser with oval ventilation hole.



EX/5/FS1/C with optional shade QEX/FS1/NAT

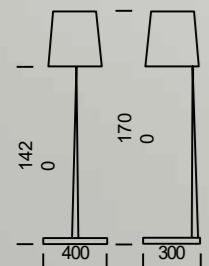

1x E27 8W LED 2700K
 CE U_L IP20

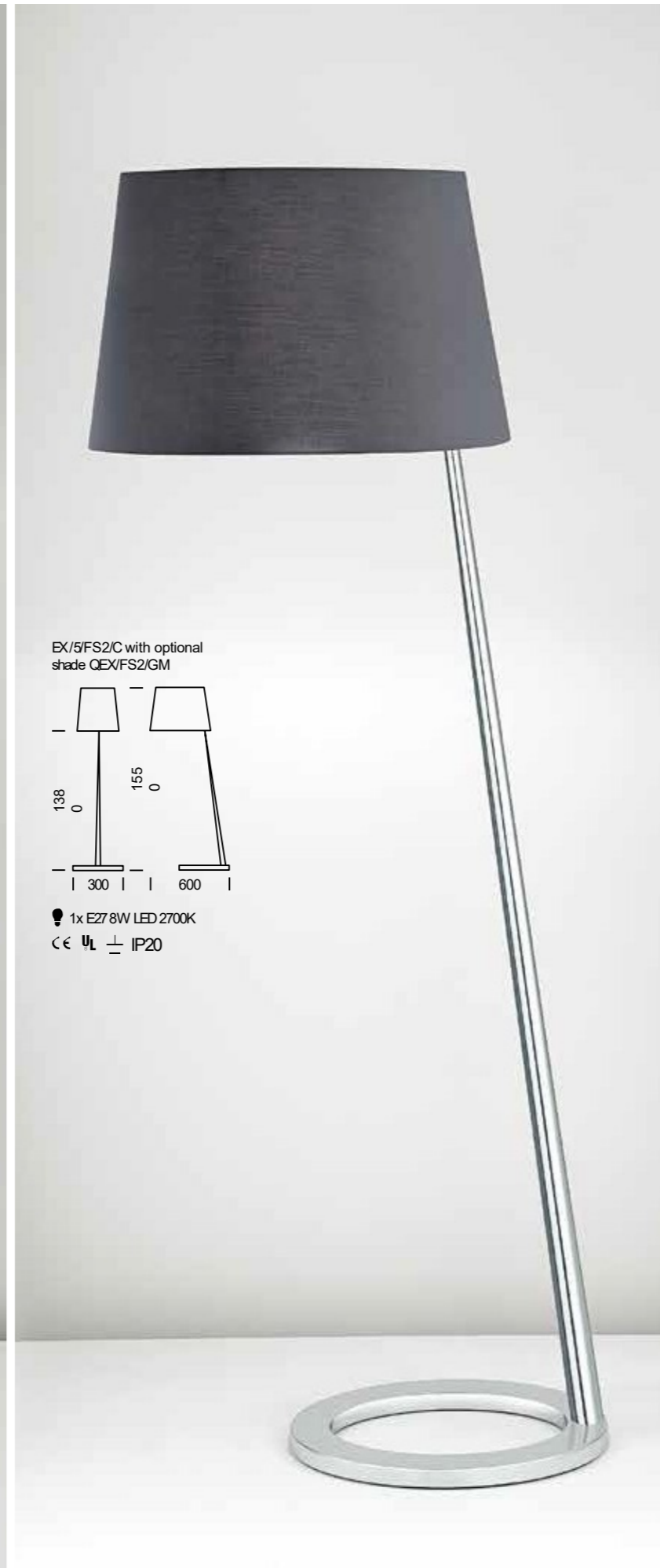

EX/5/FS2/C with optional shade QEX/FS2/GM

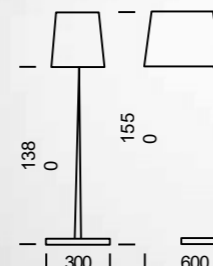

1x E27 8W LED 2700K
 CE U_L IP20



EX/5/DL/BB (custom finish) with optional shade QEX/DL/HE

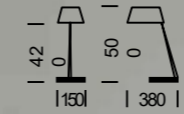

1x E27 7W LED 2700K
 CE U_L IP20



EX/5/TL/C with optional shade QEX/TL/NAT



1x E27 7W LED 2700K
 CE U_L IP20

Material:
Steel.

Finishes: Aluminium (AL) or Penny
Bronze (PBZ). Polished Chrome (C) to
special order for minimum quantities.

Shades: Shades are bespoke for the Trip range and have
integral top parchment diffusers with ventilation holes.
Other fabric options are available – see back of catalogue.

Features: Pricing and dimensions include cotton fabric shades (special fabrics may be extra).
TR/4/W1/LED/* has an integral driver and two switches, one for the main light and one for the LED
reading light. Different switching options are available to special order for minimum quantities.



TR/4/FS/PBZ with optional
shade QTRFS/OYT

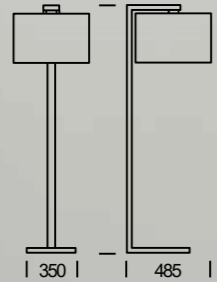

1x E27 8W LED 2700K
CE U_L IP20



TR/4/W1/LED/AL with optional
shade QTR/ W1/SHORT/ WG

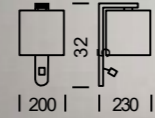

1x E27 7W LED 2700K
plus 1x LED 1W/2700K
CE U_L IP20



TR/4/W1/PBZ with optional
shade QTR/ W1/OYT

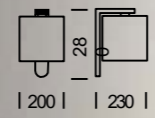

1x E27 7W LED 2700K
CE U_L IP20



TR/4/TL/PBZ with optional
shade QTR/ TL/OYT



TR/4/W1/C (custom finish) with
optional shade QTR/ W1/NAT

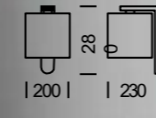

1x E27 7W LED 2700K
CE U_L IP20



TR/4/TL/AL with optional
shade QTR/ TL/ WG

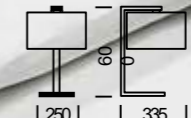

1x E27 7W LED 2700K
CE U_L IP20

Copyright 2018 Chelsom
Ltd

Material:
Steel.

Finish: Black Bronze (BB)
with others to special order
for minimum quantities.

Features: Arms can be adjusted vertically with the
shade always remaining upright. Wall light swivels
left – right. All models are switched at the lampholder.

Shades: See back of
catalogue for full range
of optional shades.

AJ/54/DL/BB with optional
shade QFD 12/LINEN ST

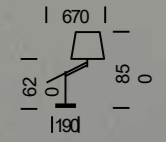

1x E27 7W LED 2700K
CE U_L IP20



Project: ADJUST at Hilton Diagonal Mar Barcelona.
Designer: The Hickson Design Partnership Ltd.



AJ/54/FS/BB with optional
shade QFD 14/LINEN NAT

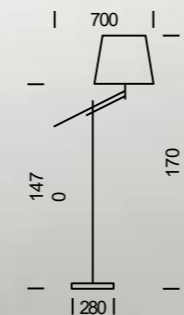

1x E27 8W LED 2700K
CE U_L IP20

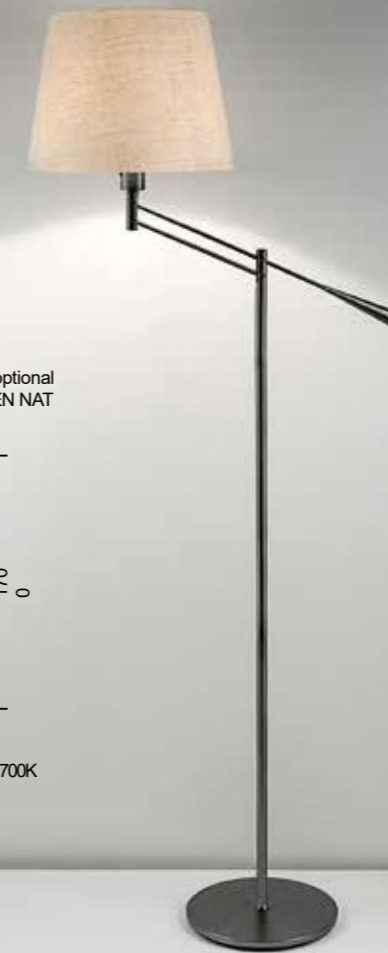

AJ/54/W1/BB with optional
shade QFD 8/LINEN BONE

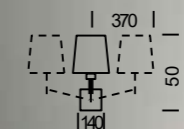

1x E27 7W LED 2700K
CE U_L IP20



Copyright 2018 Chelsom Ltd

AL/ 52/DL/ C
complete with shade

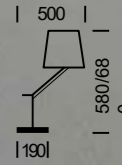

1x E27 7W LED 2700K
CE UL IP20



Project: ANGLE at Grandhotel Brussels.
Designer: Bost Group.

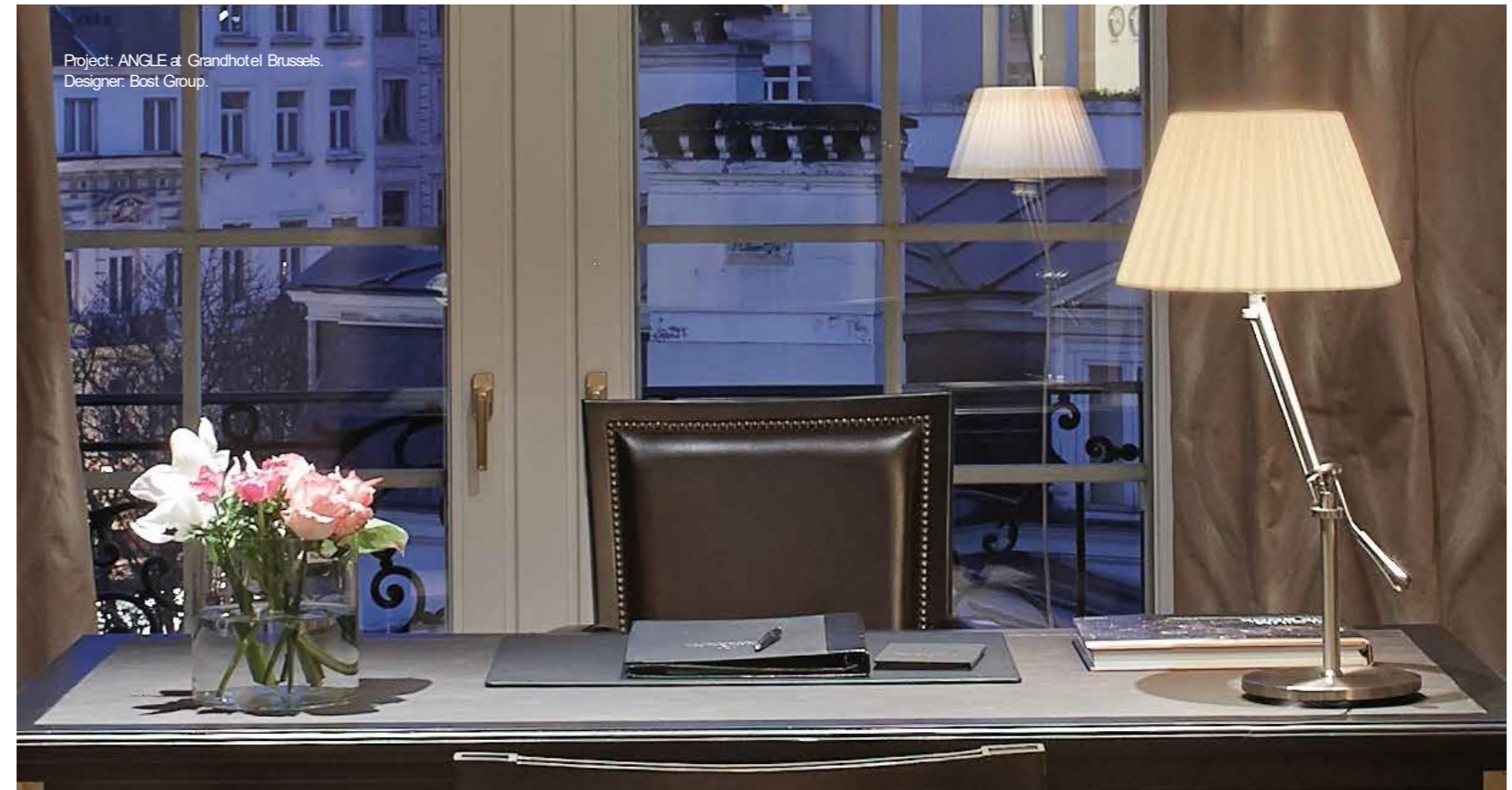

AL/ 52/FS/ C complete with shade

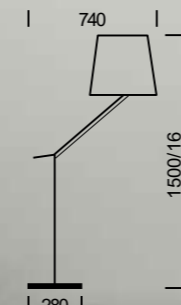

1x E27 8W LED 2700K
CE UL IP20



AL/ 52/W1/BN
complete with shade

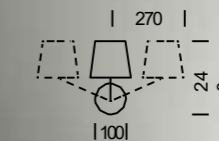

1x E27 7W LED 2700K
CE UL IP20



Material: Steel.
Finish: Satin Black with Brushed Brass.

Features: Brushed Brass accents contrast with Satin Black metalwork and tapered shades are suspended giving good downlight. The table and floor lamps sit on heavy slim bases and the combination wall light has a directional switched LED reading light with integral driver in the backplate. Fabric shades are bespoke for this range - other fabrics available.



DW/6/FS with optional shade QDW/10/NAT

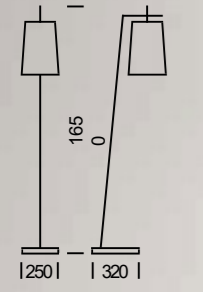

1x E27 8W LED 2700K
CE U_L IP20



DW/6/W1 with optional shade QDW/5/NAT

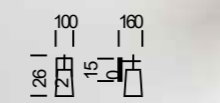

1x E27 7W LED 2700K
CE U_L IP20



DW/6/W1/LED with optional shade QDW/5/NAT

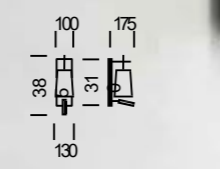

1x E27 7W LED 2700K plus 1x LED 1W 2700K
CE U_L IP20



DW/6/TL with optional shade QDW/5/NAT

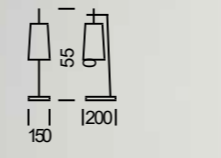

1x E27 7W LED 2700K
CE U_L IP20

Copyright 2018 Chelsom Ltd



Material:
Steel.

Finish:
Polished
Chrome.

Features: Bases and backplate feature detailed concentric grooves reminiscent of vinyl records. The retro look is enhanced by White shades with Black trim.

Materials:
Steel and
wood.

Finish: Satin
Black with
Walnut.

Features: Off centre columns for table and floor lamps sit on heavy circular bases and the range has contrasting Walnut wood sections.



Copyright 2018 Chelsom Ltd

Material:
Steel.

Finish: Satin
Black with
Aluminium.

Features: An up-and-over square section column supports bowed rectangular shades in Grey with Black trim - for other fabric options see back of catalogue. The table lamp has a rocker switch in the base as does the combination wall light which operates the LED reading light (driver is integral).

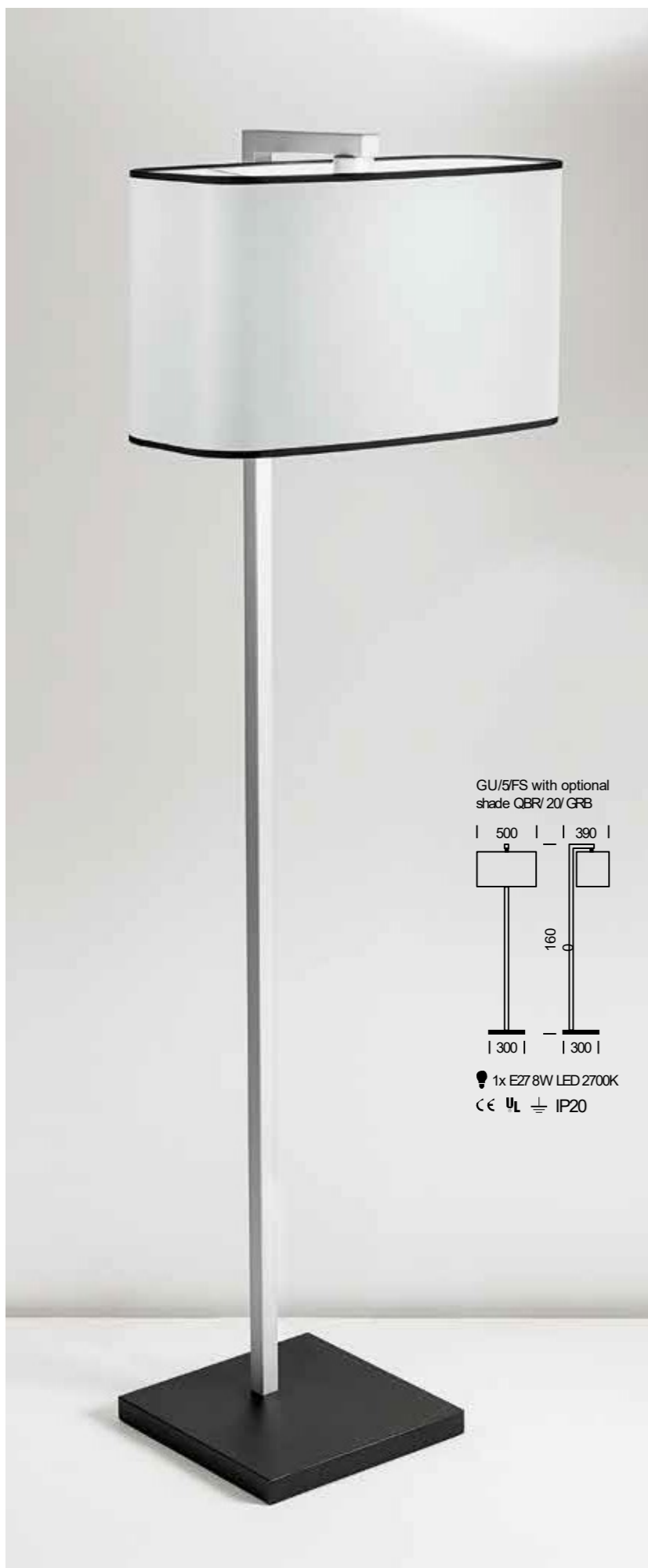

GU/5FS with optional shade QBR/ 20/ GRB

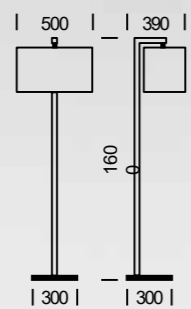

1x E27 8W LED 2700K
CE U_L IP20



GU/5/ W1/LED with optional shade QBR/ 10/ GRB

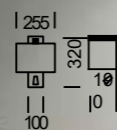

1x E27 7W LED 2700K
plus 1x LED 1W 2700K
CE U_L IP20



GU/5/ W1 with optional shade QBR/ 10/ GRB

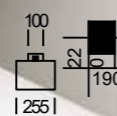

1x E27 7W LED 2700K
CE U_L IP20



GU/5/ TL with optional shade QBR/ 12/ GRB

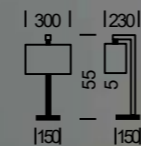

1x E27 7W LED 2700K
CE U_L IP20



Material:
Steel.

Finishes: Polished Chrome
(C) or Satin Black with
Brushed Brass (BL/BRB).

Shades: See back of
catalogue for full range
of optional shades.

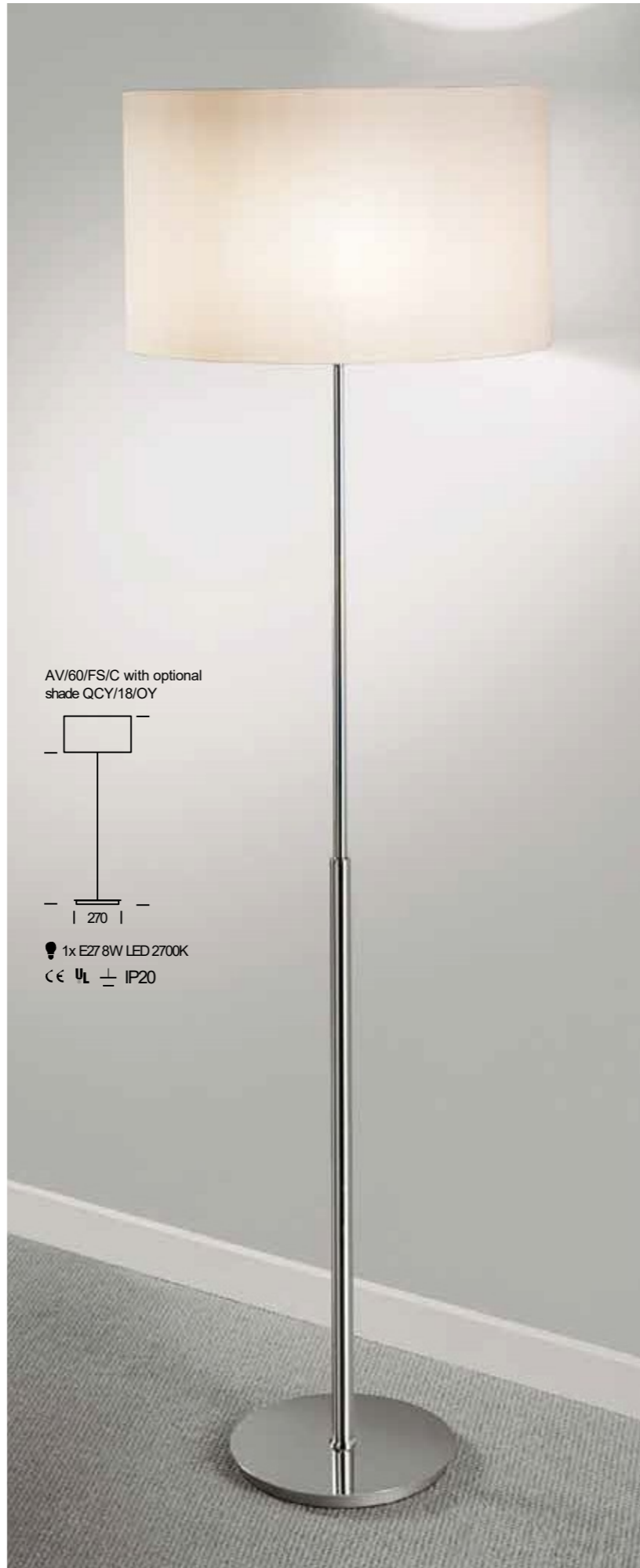

Copyright 2018 Chelsom Ltd



Material: Steel.
Finish: Polished Chrome.

Features: Desk lamp and wall reading light have adjustable swivelling heads and wall reading light arm moves left – right. P.J/9/TL/LED/C has adjustable LED reading light with integral driver and two switches in the base. See overleaf for USB and colour finish options.

Shades: See back of catalogue pages for full range of optional shades.

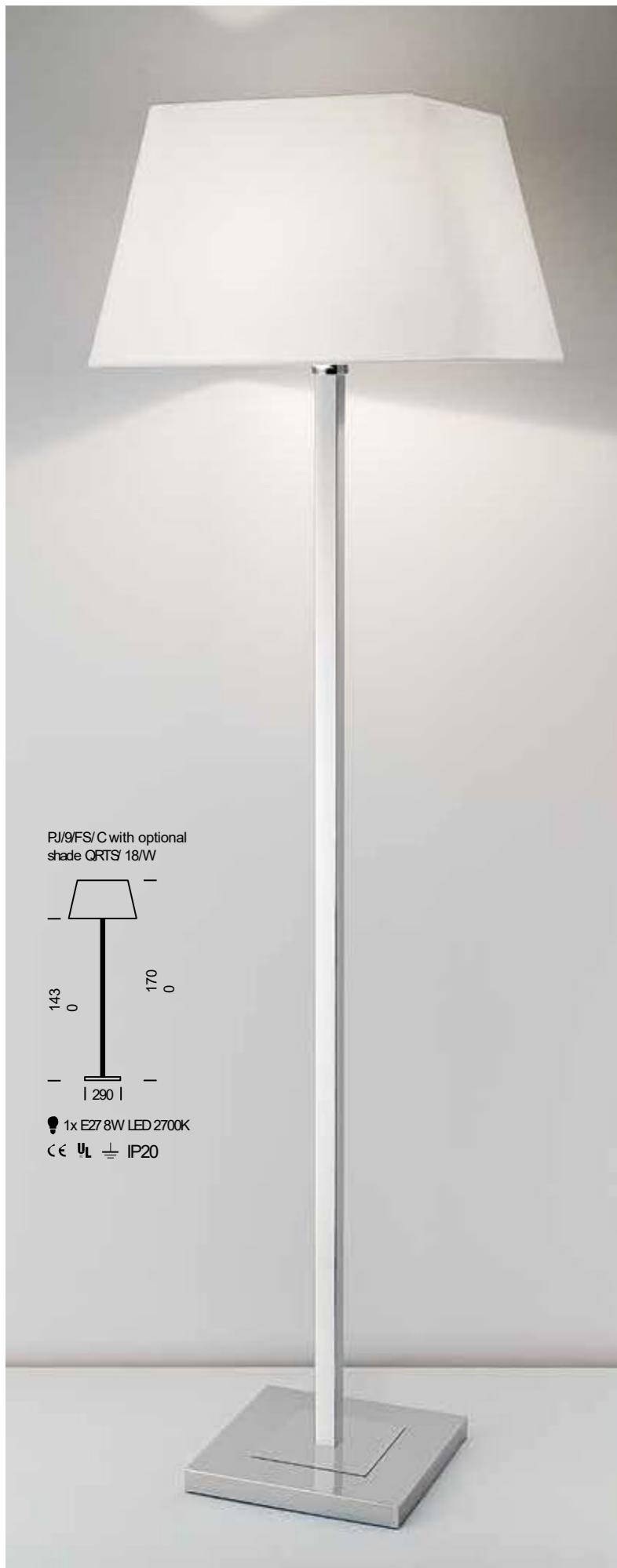

PJ/9/FS/C with optional shade QRTS/ 18/W

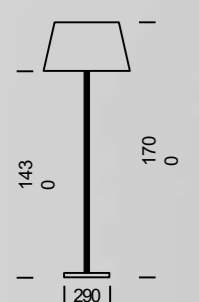

1x E27 8W LED 2700K
CE U_L IP20



PJ/9/W1/C with optional shade QRTS/ 7/HE

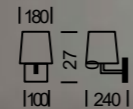

1x E27 7W LED 2700K
CE U_L IP20



PJ/9/RL/C

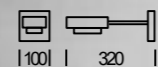

1x GX53 6W LED 2700K
CE U_L IP20



PJ/9/TL/C with optional shade QRTS/ 12/HE



1x E27 7W LED 2700K
CE U_L IP20



PJ/9/TL/LED/C with optional shade QRTS/ 12/W

1x E27 7W LED 2700K plus 1x LED 1W 2700K
CE U_L IP20

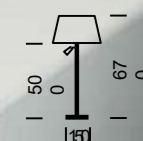

PJ/9/DL/C

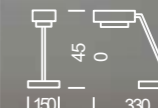

1x GX53 6W LED 2700K
CE U_L IP20

Copyright 2018 Chelsom Ltd



Steel.

Black with Brushed Brass (BL/BRB) to special order for minimum 50 pieces.

have integral USB charging port to special order for minimum 50 pieces.

Material: Steel.

Finish: Brushed Nickel.

Shades: See back of catalogue for full range of optional shades.



PLAZA

PJ/9/ TL/USB/ C with optional shade QRTS/ 12W

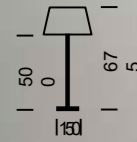

1x E27 7W LED 2700K

CE U_L IP20

(For UL please enquire.)



PJ/9/ TL/BL/BRB (custom finish) with optional shade QRTS/ 12HE

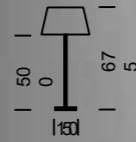

1x E27 7W LED 2700K

CE U_L IP20



PZ/4/FS with optional shade QEL/20/OY

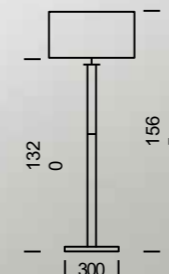

1x E27 8W LED 2700K

CE U_L IP20

Copyright 2018 Chelsom Ltd



PZ/4/W1 with optional shade QEL/10/OY

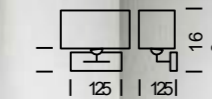

1x E27 7W LED 2700K

CE U_L IP20



PZ/4/TL with optional shade QEL/16/OY

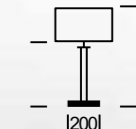

1x E27 7W LED 2700K

CE U_L IP20



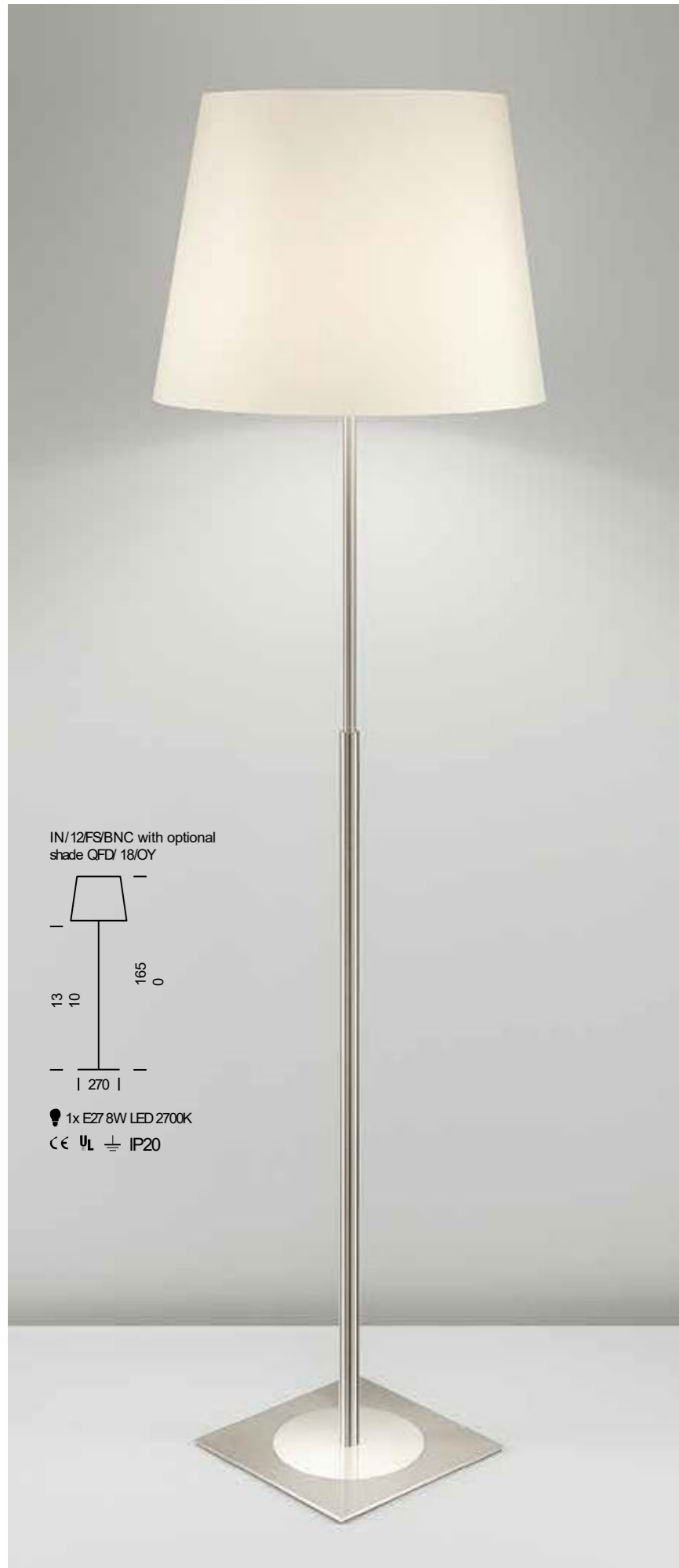

IN/12FS/BNC with optional shade QFD/18/OY

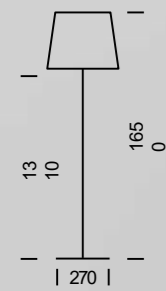

1x E27 8W LED 2700K
 CE U L IP20



IN/12W1LED/BNC with optional shade QFD/8/SLK GM

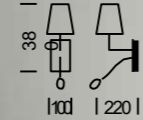

1x E27 7W LED 2700K plus 1x LED 1W/2700K
 CE U L IP20



IN/12W1/BNC with optional shade QFD/8/LINEN NAT

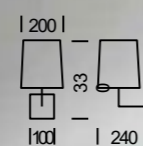

1x E27 7W LED 2700K
 CE U L IP20

Material: Steel.

Finish: A combination finish of Brushed Nickel with Polished Chrome (BNC).

Features: Round Polished Chrome plates are inset flush into square bases and backplates. Combination wall light has integral driver.

Shades: See back of catalogue for full range of optional shades.



IN/12DL/BNC

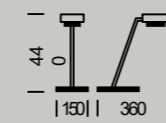

1x GX53 6W LED 2700K
 CE U L IP20



IN/12TL/BNC with optional shade QFD/10/W

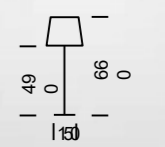

1x E27 7W LED 2700K
 CE U L IP20

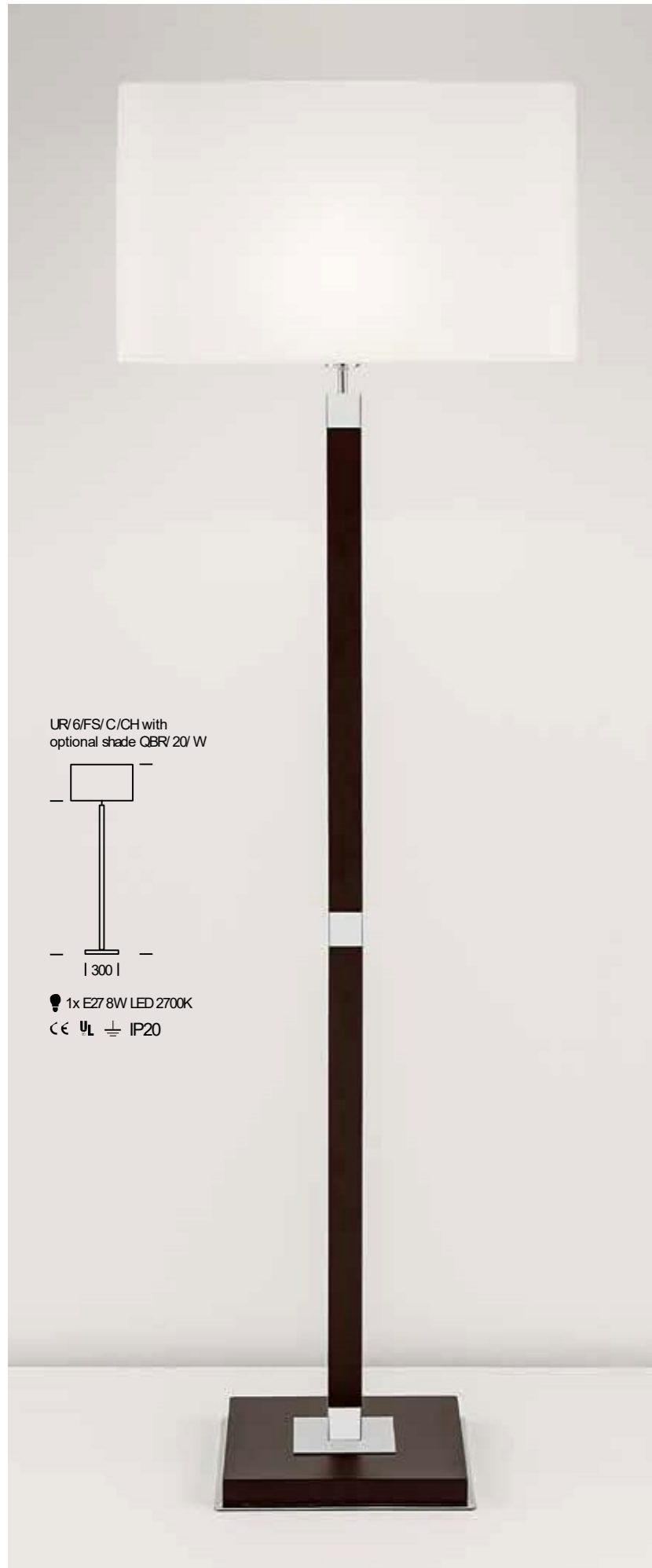

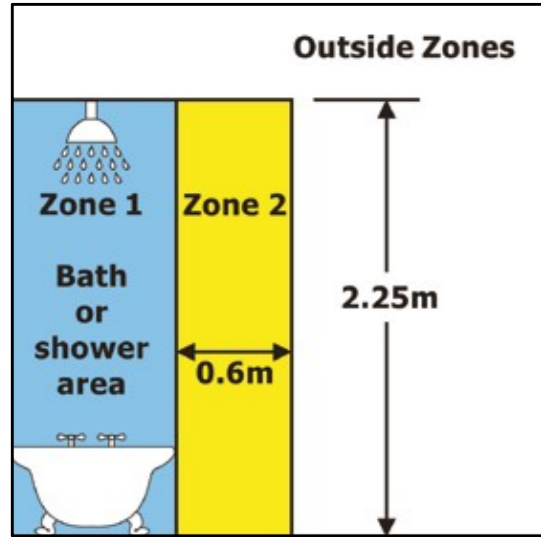

REQUIREMENTS BASED ON REGULATIONS FOR LUMINAIRES IN AREAS CONTAINING A BATH OR SHOWER

For the purpose of defining the regulations, the bathroom is divided into two zones as shown below. In any room containing a bath or shower, protection by a RCD (Residual Current Device) of 30 mA with a response time of 0.4 seconds is required for each circuit.

Zone 1

The area above that defined by the perimeter of the bath or shower tray. Only fittings supplied from a remote 12V transformer and having a minimum rating of IPx5 are recommended.

Zone 2

Area adjoining bath or shower tray. Outside the perimeter of the bath or shower up to a distance of 600mm, fittings with a minimum IPx4 rating are required, either mains or low voltage.

Outside of Zones

The remaining area of the bathroom beyond Zone 2. In this area any mains or low voltage luminaire can be used if protected by an RCD.

Only bath or shower areas are relevant in these regulations – washbasins are not. If water jets are used (this does not include shower heads), then IP55 is required.

Materials:
Steel with mirrored glass.

Finish: Polished
Chrome with white painted backboxes.

Features: Shaving mirror BW/110 is fully adjustable with an integral LED light source. Illuminated mirrors can have an optional demister pad (standard on BW/116(LED), Shaver sockets are standard on BW/115(LED)SS and BW/116(LED).

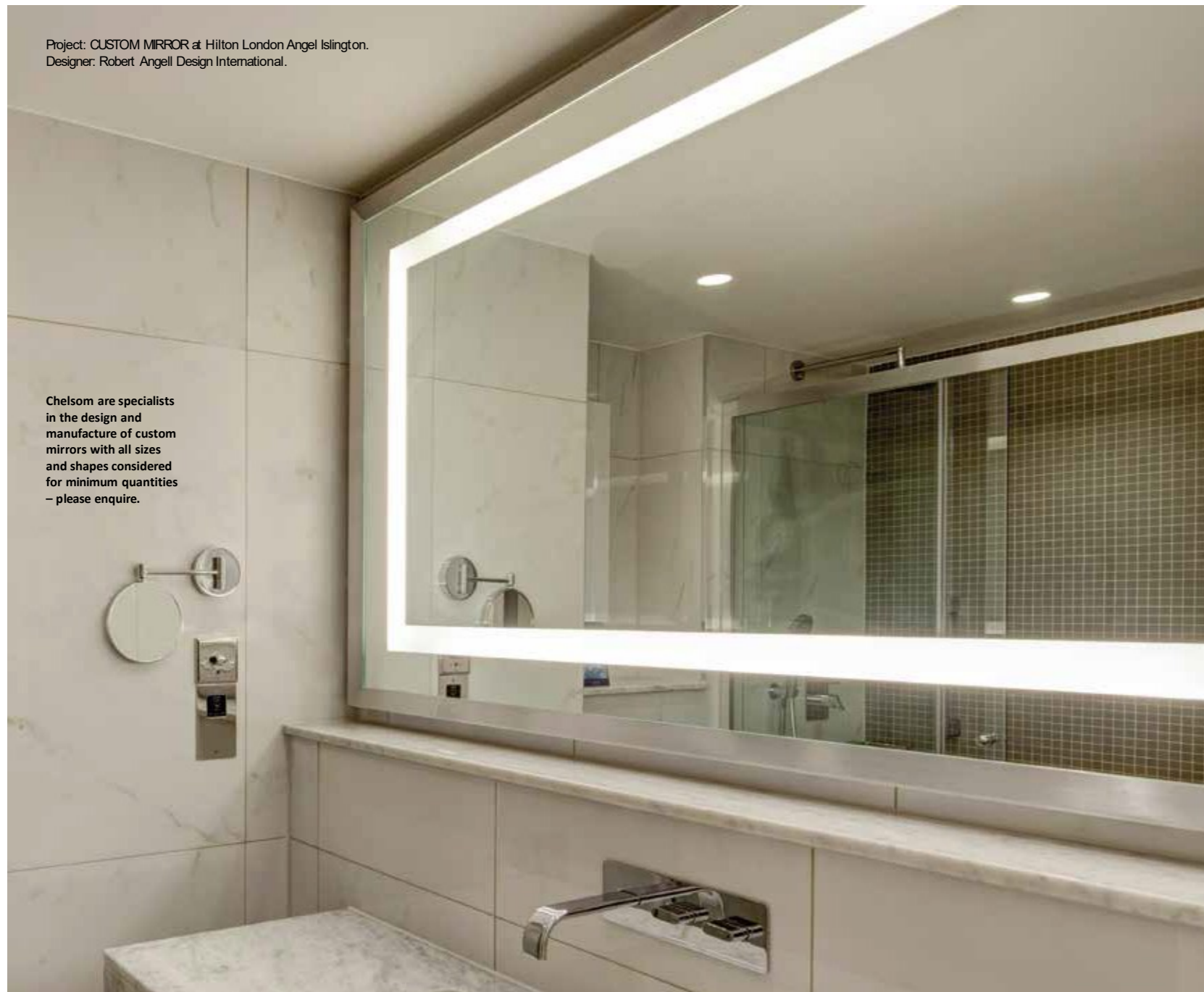

IP ratings and zone positions are shown. Please refer to the diagram on page 162.

Materials: Solid brass; Opal glass for BW/22.

Finish: Polished Nickel.

Features: Prices and dimensions include Linolux wipeable shades. G9 LED lamp housed within a waterproof frosted glass capsule.

Materials: Steel with glass diffusers.

Finishes: Polished Chrome (C) or Black Bronze (BB). Glass is Satin Opal or Clear as shown.

Features: Bathroom lighting with strong design features. RG/3 features a Clear glass cylinder, CI/37 Clear individual glass rods, LN/34 a faux stone backplate detail and OD/30 an Art Deco glass with ribbed metalwork detailing.



Copyright 2018 Chelsom Ltd



Materials:
Steel with
glass diffusers.

Finishes: Polished Chrome and BW/112 also available in
Black Bronze (BB) for minimum quantities – 50 pieces.
Diffusers are Opal, or Frosted for BW/31 models.

Features: BW/31 and BW/112 models can be vertically
or horizontally mounted. BW/20 has an enclosed,
ribbed Opal glass with integral LED light source.





Laguna 170

Laguna 172

Laguna 174

Laguna 176

Odeon 188

Paris 189

Console 190

Provence 191



Glass Art Milk 178

Glass Art Milk 179

Stockholm 180

Stockholm 182

Twist 192

Silver Sculpture 194

Elite 195

Waist 196



Oslo 184

Oslo 185

Glass Art Smoke 186

Glass Sculpture 187

Capital 197

Floor 198

Floor 198

Floor 199

Materials: Glass with steel.
 Finishes: Olive glass with Black Bronze metalwork and Gold silk-covered cable, Mocca glass with Golden Bronze metalwork and Gold silk-covered cable or Aqua glass with Brushed Nickel metalwork and Silver silk-covered cable.

Features: Rediscovered artisan glass moulds which had lain unused since the 1960s create stunning geometric patterned mouthblown glass table lamps.



Copyright 2018 Chelsom Ltd

Materials: Glass with steel.
 Finishes: Olive glass with Black Bronze metalwork and Gold silk-covered cable, Mocca glass with Golden Bronze metalwork and Gold silk-covered cable or Aqua glass with Brushed Nickel metalwork and Silver silk-covered cable.

Features: Rediscovered artisan glass moulds which had lain unused since the 1960s create stunning geometric patterned mouthblown glass table lamps.



LG/2/MOCCA with optional shade QST/20/LINEN BONE

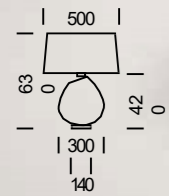

1x E27 7W LED 2700K
 CE UL IP20



Copyright 2018 Chelsom Ltd

Materials: Glass with steel.
 Finishes: Olive glass with Black Bronze metalwork and Gold silk-covered cable, Mocca glass with Golden Bronze metalwork and Gold silk-covered cable or Aqua glass with Brushed Nickel metalwork and Silver silk-covered cable.

Features: Rediscovered artisan glass moulds which had lain unused since the 1960s create stunning geometric patterned mouthblown glass table lamps.

LG/3/MOCCA with optional shade QCY/14/OY



LG/3/AQUA with optional shade QST/16/W

LG/3/OLIVE with optional shade QST/16/LINEN NAT

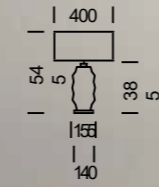

1x E27 7W LED 2700K
 CE U L IP20



Copyright 2018 Chelsom Ltd

Materials: Glass with steel.
 Finishes: Olive glass with Black Bronze metalwork and Gold silk-covered cable, Mocca glass with Golden Bronze metalwork and Gold silk-covered cable or Aqua glass with Brushed Nickel metalwork and Silver silk-covered cable.

Features: Rediscovered artisan glass moulds which had lain unused since the 1960s create stunning geometric patterned mouthblown glass table lamps.



Copyright 2018 Chelsom Ltd

Materials:
Glass and
steel.

Finish: Milk
Opal glass with
Brushed Brass.

Features: Mouthblown sculptured glass is
matched with Brushed Brass caps and bases.
Special glass colours for minimum 100 pieces.



GA/59 with optional
shade QST/18/NAT

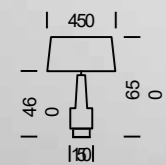

1x E27 7W LED 2700K
CE U L IP20



GA/58 with optional
shade QCY/18/NAT



1x E27 7W LED 2700K
CE U L IP20

Copyright 2018 Chelsom
Ltd

Steel and glass.

Also available in Brushed Nickel (BN) with iridescent Smoke glass – see overleaf.

and brushed metalwork with internal silk covered colour matched cables. See back of catalogue for optional shades.

SK/ 24/EBR with optional shade QST/ 18/WGO

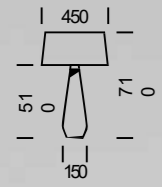

1x E27 7W LED 2700K
CE U_L IP20



SK/ 27/EBR with optional shade QCY/ 16/WGO

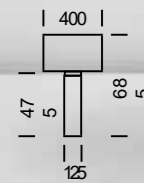

1x E27 7W LED 2700K
CE U_L IP20



SK/ 26/EBR with optional shade QST/ 18/WGO

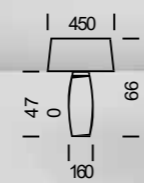

1x E27 7W LED 2700K
CE U_L IP20



Materials: Steel with glass.
 Finishes: Brushed Nickel (BN) with iridescent Smoke glass. Also available in English Brass (EBR) with Clear glass – see previous pages.

Features: Clean lines with seamless joints between glass and brushed metalwork with internal silk covered colour matched cables. SK/28 has heavy, horizontal ribbing in the metalwork.

Shades: See back of catalogue for optional shades.



SK/ 26/BN with optional shade QST/ 18/GM

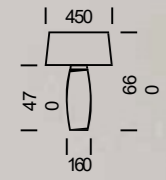

1x E27 7W LED 2700K
 CE U L IP20



SK/ 28/BN with optional shade QCY/ 16/GM

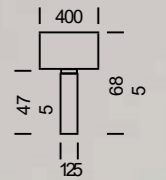

1x E27 7W LED 2700K
 CE U L IP20



SK/ 24/BN with optional shade QST/ 18/GM

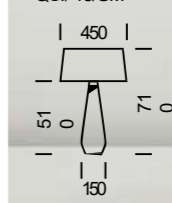

1x E27 7W LED 2700K
 CE U L IP20

Copyright 2018 Chelsom Ltd

Materials:
Glass and
steel.

Finish: Clear
glass with
English Brass.

Features: Mouthblown glass is matched with
English Brass caps and bases. Tapered perforated
brass columns feature inside the glass.

OS/9/TL with optional
shade QST/18/OY

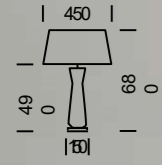

1x E27 7W LED 2700K
CE U L IP20



OS/7/TL with optional
shade QST/18/NAT

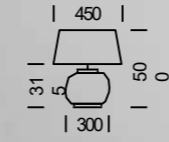

1x E27 7W LED 2700K
CE U L IP20



Copyright 2018 Chelsom
Ltd

Materials: Mouth blown Veneto glass with steel metalwork.

Finish: Smoke glass with Black Bronze metalwork.

Features: Mouth blown heavy glasses have a random horizontal ribbing. Silk covered cable runs internally.

formed Veneto solid glass with dual colours and steel metalwork.

glass and Black Bronze metalwork. Also available with Chrome metalwork.

glass outer is hand sculpted, making every piece unique with slight variations in shape and blend of colours. Silver silk covered cable runs externally.

GA/44/SM with optional shade QCY/18/LINEN NAT

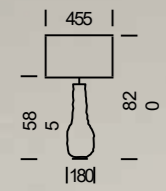

1x E27 7W LED 2700K
CE U_L IP20



GA/33/SM with optional shade QCY/14/LINEN/ST

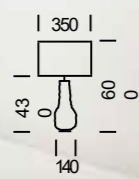

1x E27 7W LED 2700K
CE U_L IP20

GS/66/SM with optional shade QCY/14/SILK PEBBLE

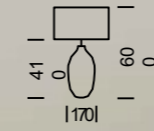

1x E27 7W LED 2700K
CE U_L IP20



Materials: Glass and steel. Finishes: Satin Opal glass with Brushed Brass (BRB) or Polished Chrome (C). Features: Art Deco style mouthblown glass sits in ribbed Brushed Brass or Polished Chrome detailing. Table lamps have stepped bases.

OD/ 30' TL/BRB



1x E27 7W LED 2700K
CE U_L IP20



OD/ 30' TL/ C



OD/ 30' W1/BRB

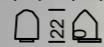
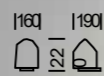

1x E27 7W LED 2700K
CE U_L IP44



Materials: Glass and brass. Finish: Polished Brass with faux marble. Features: Mouthblown clear glass globes with internal LED filament lamps screw down onto faux marble bases or backplate. The globes are encased in a Polished Brass tubular box. THE RANGE IS PRICED WITH AND COMES COMPLETE WITH LAMPS AS SHOWN.

FA/ 18/W1

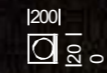

1x E14 3W LED 2200K
CE U_L IP20



FA/ 18/TL

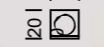

1x E14 3W LED 2200K
CE U_L IP20



Copyright 2018 Chelsom Ltd

CONSOLE

Materials:
Steel and brass.

Finishes: Black Bronze
with English Brass (BB/EBR)
or Polished Chrome (C).

Features: A tall slender lamp
for use on narrow consoles,
side tables or nightstands.

Shades: See back
of catalogue for
optional shades.



CO/9/C with optional
shade Q009/NAT

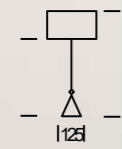

1x E27 7W LED 2700K
CE U_L IP20



CO/9/BB/EBR with
optional shade Q9/7/HE

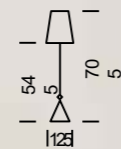

1x E27 7W LED 2700K
CE U_L IP20

PROVENCE

Materials:
Steel and
stone.

Finish: Brushed Brass
metalwork with
natural stone base.

Features: Rectangular section tubes are formed
into geometric patterns and for the table lamps
are set onto heavy natural stone bases.



PR/24/TL with optional
shade QEL/18/HE

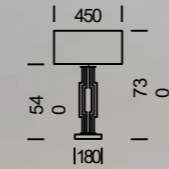

1x E27 7W LED 2700K
CE U_L IP20



PR/24/W1 with
optional shade
QPRW1/LINEN NAT

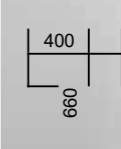

1x E27 7W LED 2700K
CE U_L IP20

Materials:
Wrought iron
and steel.

Finishes: Florentine Antique
Gold Leaf (GO) and Florentine
Antique Silver Leaf (SI).

Features: Hand wrought iron tubing with a distressed patina is formed
into a twisted shape and for each model two arms support offset
fabric shades. Table and floor lamp rectangular bases are Satin Black.

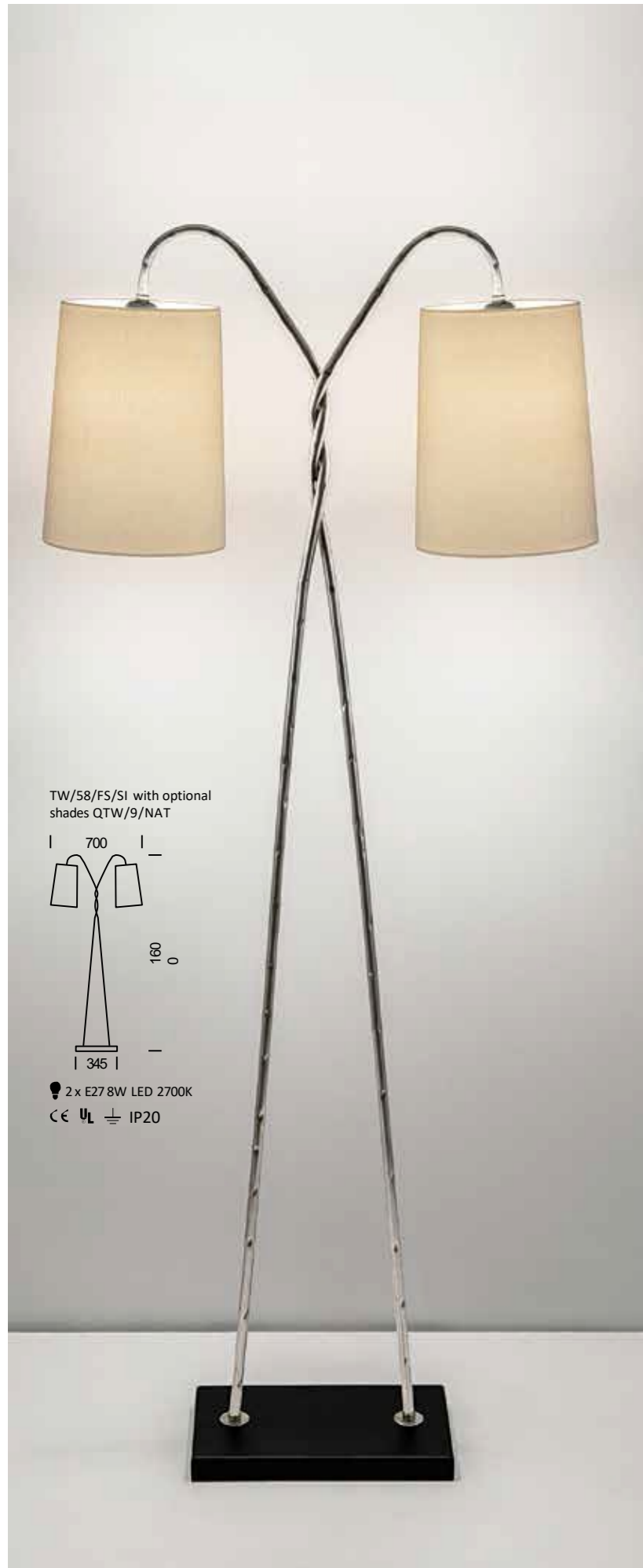

TW/58/FS/SI with optional
shades QTW/9/NAT

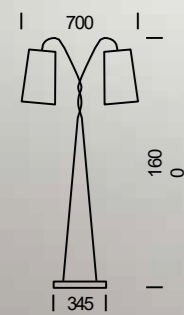

2 x E27 8W LED 2700K
CE U_L IP20



TW/58/W2/GO with optional
shades QTW/5/LINEN NAT

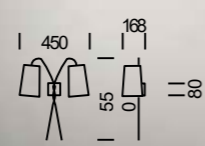

2 x E27 7W LED 2700K
CE U_L IP20



TW/58/TL/SI with optional
shades QTW/5/NAT

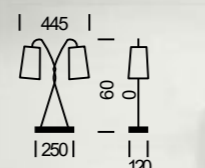

2 x E27 7W LED 2700K
CE U_L IP20

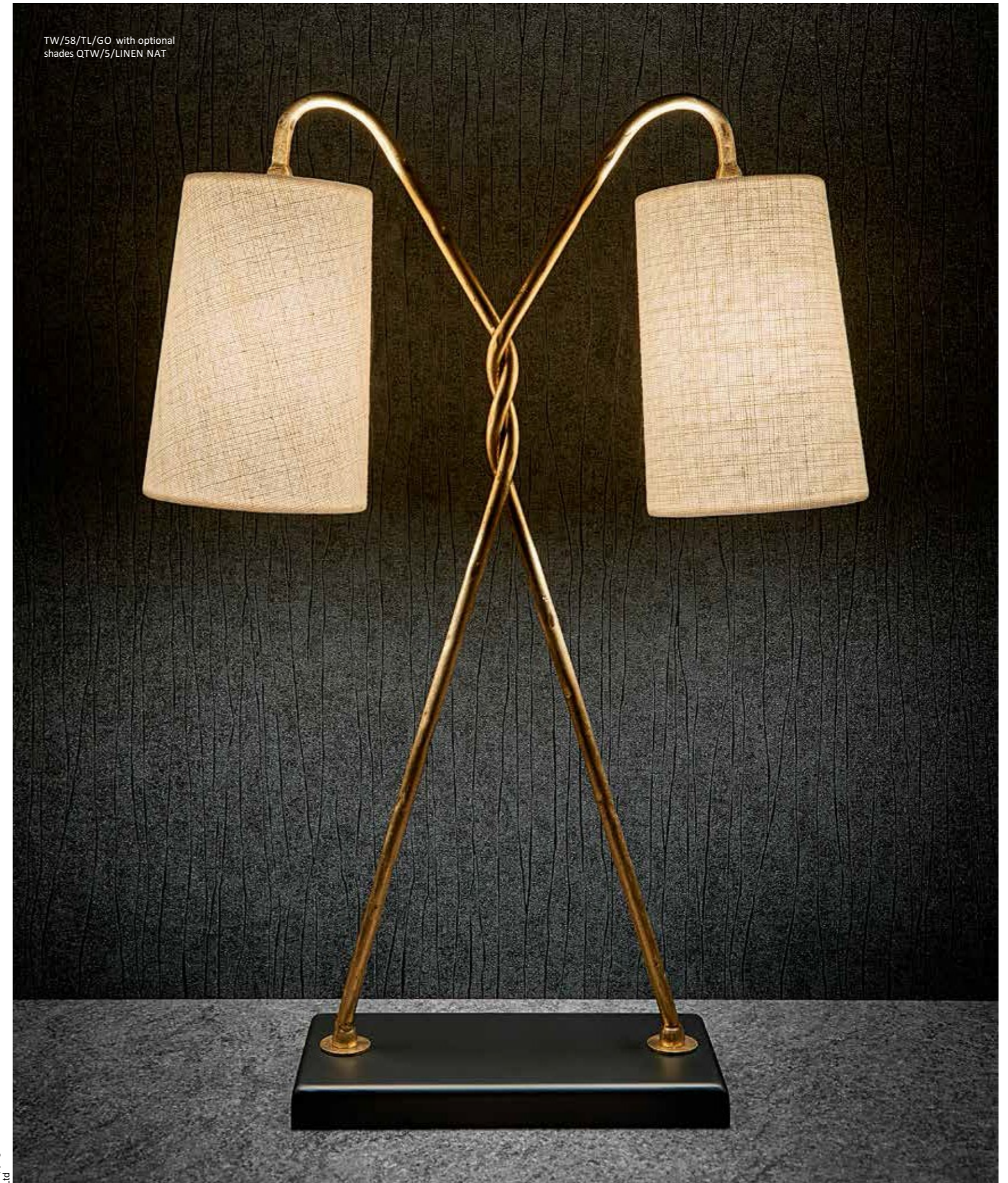

TW/58/TL/GO with optional
shades QTW/5/LINEN NAT

Copyright 2018 Chelsom
Ltd

Material: Hand forged iron.	Finish: Florentine Antique Silver Leaf.	Features: See also Silver Sculpture matching pendants and wall lights.	Shades: See back of catalogue for optional shades.
--------------------------------	--------------------------------------------	------------------------------------------------------------------------	----------------------------------------------------



SS/90/FS with optional shade QCY/20/SILK PEBBLE



1x E27 8W LED 2700K
CE U_L IP20

SS/90/TL with optional shade QCY/16/SILK PEBBLE

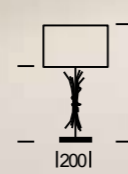

1x E27 7W LED 2700K
CE U_L IP20

Materials: Solid cast metal and brass.	Finishes: Subtle Antique Brass with Gunbarrel Bronze accents.	Shades: See back of catalogue for optional shades.
-------------------------------------------	------------------------------------------------------------------	----------------------------------------------------



CN/12083/AB/BZ with optional shade QST/16/LINEN NAT

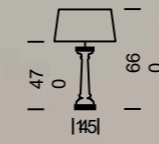

1x E27 7W LED 2700K
CE U_L IP20

WAIST

Material:
Steel.

Finish: Textured
Black with Polished
Chrome ring.

Features: Heavy bases and solid
steel bars in a 'waisted' design
with external chrome ring.

Shades: See back
of catalogue for
optional shades.

Steel.

with Antique Brass
accents.

design stands on flat circular bases. Cable
runs internally down one of the legs.

WA/31/FS with optional
shade QWA/18/BS

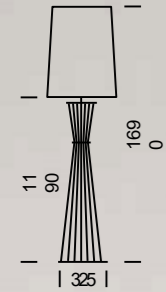

1x E27 8W LED 2700K
CE U_L IP20



WA/31/TL with optional
shade QWA/12/OYB

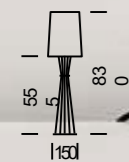

1x E27 7W LED 2700K
CE U_L IP20

CT/4/FS with optional shade
QST/24/LINEN NAT

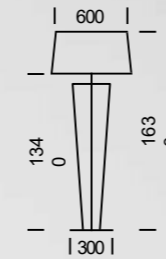

1x E27 8W LED 2700K
CE U_L IP20



CT/4/TL with
optional shade
QST/18/LINEN NAT

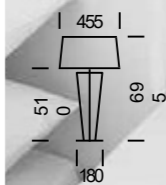

1x E27 7W LED 2700K
CE U_L IP20

Copyright 2018 Chelsom
Ltd

Materials: Wood and steel.
 Finishes: Polished Chrome on FA/70 with Wenge wood on FA/30 and Walnut on FA/80.

Features: FA/30 has cable running internally down one leg. FA/70 has an extremely heavy base for stability with dimensions including a special shade with integral bottom diffuser, priced separately. FA/80 has a curved tripod base supporting Polished Chrome decorative capping. Top of lamp also has decorative Chrome accents.

Shades: See back of catalogue for optional shades.

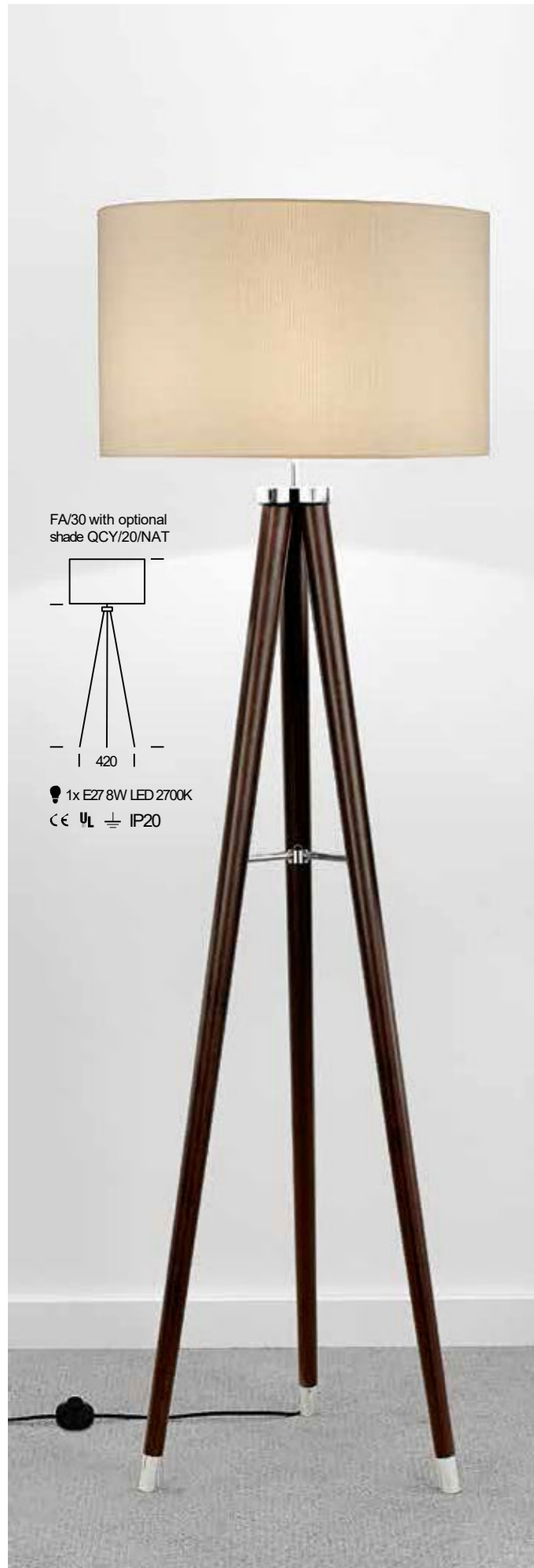

FA/30 with optional shade QCY/20/NAT

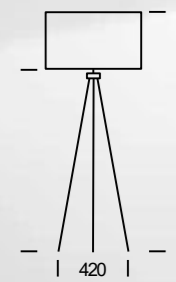

1x E27 8W LED 2700K
 CE U_L IP20



FA/70 complete with optional shade QFA/70/ST

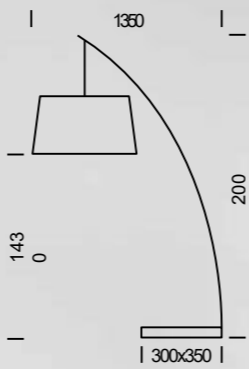

1x E27 8W LED 2700K
 CE U_L IP20



FA/80 with optional shade QST/24/OY

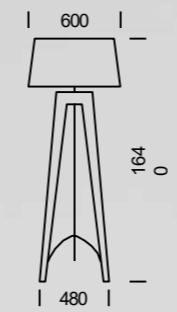

1x E27 8W LED 2700K
 CE U_L IP20

Copyright 2018 Chelsom Ltd



The Chelsom Value Award is given to ranges which represent exceptional value alongside high design and quality standards.



Icicle 202



Sirius 206



Orb 208



Halo 210



Halo 212



Custom Laser 244



Custom Galaxy 246



Teardrop 248



Silver Sculpture 250



Palm 254



Pear 213



Criterion 214



Oxford 216



Arcade 218



Radar 220



Artichoke 256



Glasgow 258



London 260



Ailsa 262



Space 264



Capri 221



Regent 222



Aura 223



Constellation 224



Atlanta 226



Welcome 266



Snap VA 269



Solar 270



Reflector 272



Sconce 274



Laguna Pendants 227



Laguna Pendants 228



Laguna Pendants 230



Glass Pendants 231



Pendants 232



Hoop 275



Feature Wall Lights 276



Highlands 282



Metal Sculpture 283



Classic Picture Lights 284



Custom Crown 236



Custom Flare 238



Custom Diamond 239



Custom Rods 240



Custom Filament 242



Picture Lights 285



Sparkle 286



Kensington Lanterns 287



Mayfair Lanterns 288



Classic Exterior 290

Copyright 2018 Chelsom Ltd

Materials: Steel and glass.
 Finish: English Brass with silver-flecked clear glass.

Features: Dimmable integral LED light sources in the base of the glass icicles throw light upwards giving a warm ambient glow whilst reflecting off the tiny silver leaf flecks within the handmade glass. Alternate arms curve upwards or downwards to give a random feel to the heights of the icicle glasses. Note: Glass icicles are handmade and may have slight variations.

IC/24/3+3
 180
 Min 870/Max 2750
 600
 Weight 13kg
 6 x LED 3W 2700K
 CE IP20
 (For UL please enquire.)



IC/24/12+6
 230
 Min 1150/Max 3030
 1200
 Weight 35kg
 18 x LED 3W 2700K
 CE IP20
 (For UL please enquire.)



Copyright 2018 Chelsom Ltd

Materials:
Steel and glass.

Finish: English Brass
with silver-flecked
clear glass.

Features: Dimmable integral LED light sources in the base of the glass icicles throw light upwards giving a warm ambient glow whilst reflecting off the tiny silver leaf flecks within the handmade glass (single pendant non-dimmable). Alternate arms curve upwards or downwards to give a random feel to the heights of the icicle glasses. Pendant IC/24/P gives a warm downlight glow. Note: Glass icicles are handmade and may have slight variations.



IC/24/6+6
200
1000
Min 870/ Max 2750
Weight 24kg
12x LED 3W 2700K
CE IP20
(For UL please enquire.)



IC/24/W2
245 230
70
2x LED 3W 2700K
CE IP20
(For UL please enquire.)



IC/24/P
18
Min 670/ Max 2630
70
Weight 1.8kg
LED 3W 2700K
CE IP20
(For UL please enquire.)

Copyright 2018 Chelsom Ltd

Material:
Steel.

Finish:
Brushed
Brass.

Features: A starburst effect is created from a central globe which supports LED cigar filament lamps and folded tapering brass reflector fins. Each fin can rotate to create a random effect.
THE RANGE IS PRICED WITH AND COMES COMPLETE WITH LAMPS AS SHOWN.

SB/44/6



Weight 2.6kg
6 x E27 4W LED 2200K
UL IP20



SB/44/8



Weight 5kg
8 x E27 4W LED 2200K
UL IP20



Copyright 2018 Chelsom Ltd

Materials:
Steel and
glass.

Finish: Brushed Brass
with Satin Black and
Matt Opal glass.

Features: Opal globes have a screw connection into Brushed Brass bowls which are perforated with a houndstooth pattern allowing spills of light to shine through. These are supported by curved arms extending from substantial Brushed Brass rings. Chandeliers hang on three strainer wires adjustable for height during installation.

OR/41/6



OR/41/10

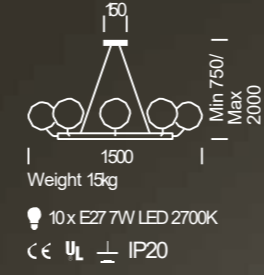

OR/41/P



OR/41/W1

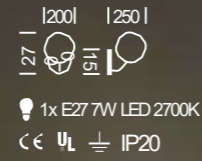

Copyright 2018 Chelsom Ltd

Materials: Steel.
Finish: Brushed Brass with Satin Black.

Features: Decorative LED filament lamps reflect a warm glow off the interiors of Brushed Brass rings. The rings on the four and eight light chandeliers can rotate at the end of the arms to give a random appearance. The ten light has rings suspended on black silk-covered cable to look similarly random. See overleaf for matching wall lights. THE RANGE IS PRICED WITH AND COMES COMPLETE WITH LAMPS AS SHOWN.

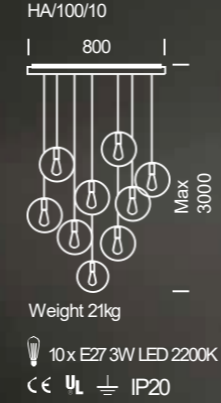

Copyright 2018 Chelsom Ltd

Material: Steel.
Finish: Brushed Brass with Satin Black.

Features: Decorative LED filament lamps reflect a warm glow off the interiors of Brushed Brass rings. See previous pages for matching chandeliers. HA/100/W1A can be installed vertically or horizontally. THE RANGE IS PRICED WITH AND COMES COMPLETE WITH LAMPS AS SHOWN.

vertically or horizontally. THE RANGE IS PRICED WITH AND COMES COMPLETE WITH LAMPS AS SHOWN.



HA/100/W1

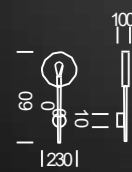

1x E27 3W LED 2200K
CE UL IP20



HA/100/W2

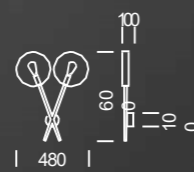

2x E27 3W LED 2200K
CE UL IP20



HA/100/W1A

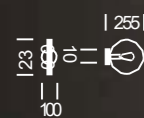

1x E27 3W LED 2200K
CE UL IP20

Materials: Glass and Steel.
Finish: Brushed Brass with Clear Crackle glass.

Features: Tiny points of LED light project a sparkling glow into sculptured crackle glass pears. A single pendant and five light cluster with top plate are illustrated and large custom cascades or spirals are available to special order.

PX/14/5P



Weight 5kg
5x LED 3W 2700K
CE UL IP20
(For UL please enquire.)



PX/14/P

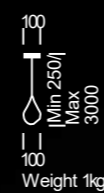

LED 3W 2700K
CE UL IP20
(For UL please enquire.)

Materials:
Glass and
steel.

Finishes: Polished
Brass (FB) or Polished
Chrome (C).

Features: Dimmable integral LED light sources sparkle and refract through individual solid clear glass rods. Faux alabaster acrylic bottom diffusers give a soft downlight. The range has a matching bathroom wall light – see page 165.

CI/38/SF/PB

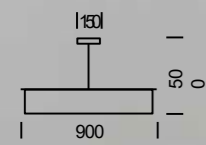

Weight 23kg

LED 22W 2700K

CE IP20

(For UL please enquire.)



CI/35/F/C

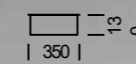

Weight 6kg

LED 8W 2700K

CE IP20

(For UL please enquire.)



CI/35/SF/C

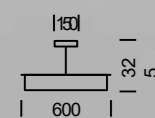

Weight 13kg

LED 10W 2700K

CE IP20

(For UL please enquire.)



CI/35/W2/PB

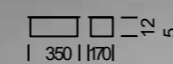

LED 6W 2700K

CE IP20

(For UL please enquire.)



CI/36/W2/PB

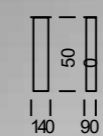

LED 9W 2700K

CE IP20

(For UL please enquire.)



Materials: Steel and glass.
 Finish: Brushed Brass (BRB) with glasses in Opal (OP) or Clear Crackle (CR).

Features: Simple elegant sweeping arms with Satin Opal or Clear Crackle glass globes are equally at home in a traditional or contemporary setting. Glasses have integral threaded metal fixings for secure attachment. Wall lights can be installed as up or down lights.
 WHEN SUPPLIED WITH CLEAR CRACKLE GLASSES, THE FITTINGS ARE PRICED WITH AND COME COMPLETE WITH LAMPS AS SHOWN.



OX/42/3/BRB with optional glass GS/200/OP
 Min 650 Max 2520
 540
 Weight 5kg
 3 x E27 7W LED 2700K
 CE U L IP20



OX/42/6/BRB with optional glass GS/200/CR
 Min 800 Max 2670
 1000
 Weight 8kg
 6 x E27 3W LED 2200K
 CE U L IP20



OX/42/W1/BRB with optional glass GS/200/OP
 200 | 295 |
 1 x E27 7W LED 2700K
 CE U L IP20



OX/42/W1/BRB with optional glass GS/200/OP
 200 | 295 |
 1 x E27 7W LED 2700K
 CE U L IP20



OX/42/W2/BRB with optional glass GS/200/CR
 460 | 240 |
 1.30 | 1.15 |
 2 x E27 3W LED 2200K
 CE U L IP20

Copyright 2018 Chelsom Ltd

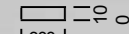
AD/35/FF

 | 300 |
 Weight 1.85kg
 LED 10W 2700K
 CE IP20
 (For UL please enquire.)

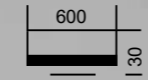

AD/35/FF2

 600
 | 300 |
 130
 Weight 8kg
 LED 16W 2700K
 CE IP20
 (For UL please enquire.)



AD/35/WW

 | 285 |
 100
 LED 8W 2700K
 CE IP20
 (For UL please enquire.)



Copyright 2018 Chelsom Ltd

Material: Steel.
Finish: English Brass with Satin Black.

Features: Shallow perforated metal coolie shades are supported by detailed knurled lampholder covers and contain LED squirrel cage filament lamps. RA/5/W1 has a directional head. RA/4/W1 can be ceiling mounted. See page 41 for matching table lamp. THE RANGE IS PRICED WITH AND COMES COMPLETE WITH LAMPS AS SHOWN.

RA/4/P
| 100 |
| 270 |
Weight 1kg
1x E27 3W LED 2200K
CE UL IP20



RA/5/W1
| 23 |
| 315 |
1x E27 3W LED 2200K
CE UL IP20



RA/4/W2
| 60 |
| 270 |
| 236 |
2x E27 3W LED 2200K
CE UL IP20

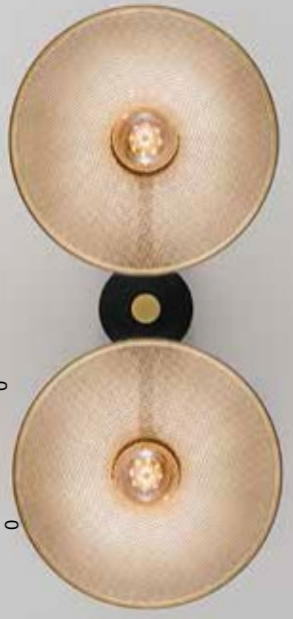

RA/4/W1
| 270 | | 220 |
1x E27 3W LED 2200K
CE UL IP20



Materials: Steel and glass.
Finishes: Brushed Brass (BRB) or Black Bronze (BB) with frosted Opal glass.

Features: Heavily ribbed Opal glass shades are secured onto knurled decorative double-stepped caps. The wall light can be installed as an up or downlighter. Light sources are integral warm white LED. CP/24/P has a fixed suspension rod which can divide into three connectable parts (250mm, 400mm or 600mm).

CP/24/4/BRB
| 120 |
| 940 |
Weight 11kg
4x LED 8W 2700K
CE UL IP20
(For UL please enquire.)

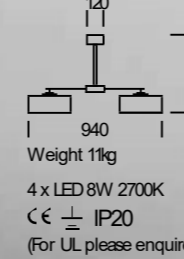

CP/24/W1/BRB
| 250 | | 300 |
| 150 |
LED 8W 2700K
CE UL IP20
(For UL please enquire.)

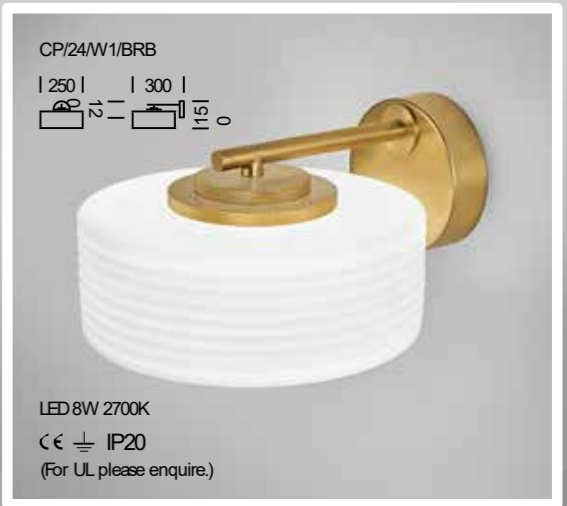

CP/24/FF/BB
| 155 |
| 140 |
| 250 |
LED 8W 2700K
CE UL IP20
(For UL please enquire.)

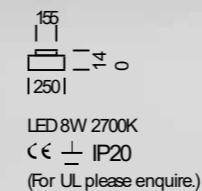

CP/24/P/BB
| 120 |
| 250 |
Min 450
Max 1500
Weight 2kg
LED 8W 2700K
CE UL IP20
(For UL please enquire.)

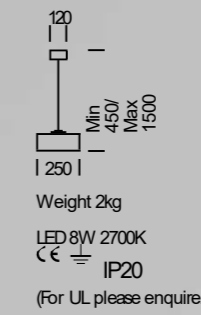

Copyright 2018 Chelsom Ltd

REGENT

Materials:
Steel and glass.

Finishes: English Brass (EBR)
or Black Bronze (BB) with
Clear and Frosted glass.

Features: Dimmable integral LED light sources shine light upwards into heavily frosted glass candles which are seen through sparkling clear glass outer chimneys (wall light non-dimmable). The glass chimneys sit in hexagonal cups and have delicate metal top caps.

RG/3/6/EBR



Weight 11kg

6 x LED 3W 2700K

CE IP20

(For UL please enquire.)



RG/3/W1/EBR

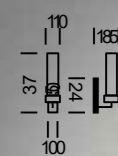

1x LED 3W 2700K

CE IP44

(For UL please enquire.)



RG/3/W1/BB

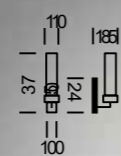

1x LED 3W 2700K

CE IP44

(For UL please enquire.)



Materials:
Steel and
resin.

Finish:
Brushed
Brass.

Features: A curved Brushed Brass ring conceals LED points of light which shine outwards illuminating individual faux rock crystals to give a highly ambient light effect. The ceiling fitting is suspended from fine strainer wires adjustable for height during installation and the wall light can be mounted horizontally or vertically.

AURA

AU/22/P

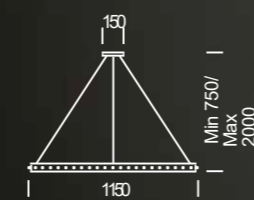

LED 18W 2400K

Weight 18kg

CE IP20

(For UL please enquire.)



AU/22/WW

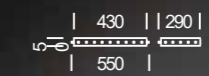

LED 5W 2400K

CE IP20

(For UL please enquire.)



Materials:
Steel and
glass.

Finish: Brushed
Brass with Matt
Opal glass.

Features: Ceiling fittings with an organic design giving a random pattern of arms and Opal globes. Glasses have threaded inserts to screw on for a durable fixing. Custom designs and sizes can be manufactured.



Copyright 2018 Chelsom Ltd

Materials: Steel, acrylic and fabric.

Finishes: Brushed Brass (BRB) and Polished Chrome (C).

Features: Semi-flush ceiling fittings have matt opal acrylic diffusers and off white textured cotton fabric shades.

AT/85/P/BRB

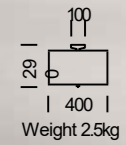

1x E27 7W LED 2700K
CE U_L IP20



AT/85/P/C

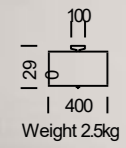

1x E27 7W LED 2700K
CE U_L IP20



Materials: Glass with steel.

Finishes: Olive glass with Black Bronze metalwork and Black silk-covered cable or Mocca glass with Golden Bronze metalwork and Black silk-covered cable.

Features: Rediscovered artisan glass moulds create stunning geometric patterned mouthblown glass pendants. Suspension units have knurled detailing. PRODUCTS ARE PRICED WITH AND COME COMPLETE WITH LAMPS AS SHOWN.

LG/1P/MOCCA

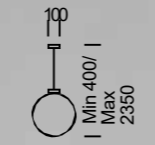

1x E27 4W LED 2200K
CE U_L IP20



LAGUNA PENDANTS

Materials: Glass with steel.
 Finishes: Olive glass with Black Bronze metalwork and Black silk-covered cable or Mocca glass with Golden Bronze metalwork and Black silk-covered cable.

Features: Rediscovered artisan glass moulds which had lain unused since the 1960s create stunning geometric patterned mouthblown glass pendants. Suspension units have knurled detailing. PRODUCTS ARE PRICED WITH AND COME COMPLETE WITH LAMPS AS SHOWN.

LAGUNA PENDANTS



LG/3P/OLIVE

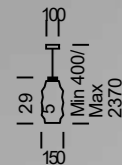

Weight 2kg

1x E27 4W LED 2200K
 CE U_L IP20

LG/3P/MOCCA



LG/5P/OLIVE

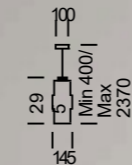

Weight 2kg

1x E27 4W LED 2200K
 CE U_L IP20

LG/5P/MOCCA

LAGUNA PENDANTS

Glass with steel.

Brushed Nickel metalwork and Silver silk-covered cable.

geometric patterned mouthblown glass pendants. Suspension units have knurled detailing. PRODUCTS ARE PRICED WITH AND COME COMPLETE WITH LAMPS AS SHOWN.

LG/5P/AQUA

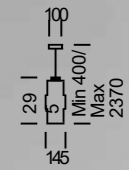

Weight 2kg

1x E27 4W LED 2200K
 CE U_L IP20



LG/3P/AQUA

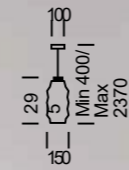

Weight 2kg

1x E27 4W LED 2200K
 CE U_L IP20



Glass with steel.

Brushed Brass metalwork and Gold silk-covered cable.

since the 1960s create stunning geometric patterned mouthblown glass pendants. Suspension units have knurled detailing above the glass.

GP/10

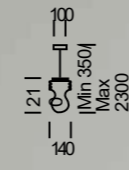

Weight 1.5kg

1x E27 7W LED 2700K
 CE U_L IP20



GP/11

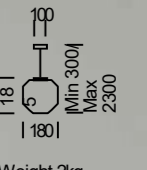

Weight 2kg

1x E27 7W LED 2700K
 CE U_L IP20



SG/ 25/P/ C with optional shade QSG/ 7 OY

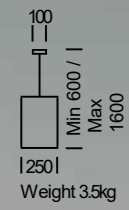

Weight 3.5kg
 1x E27 7W LED 2700K
 CE U L IP20
 See pages 60-64 for full range.



SG/ 24/P/BB

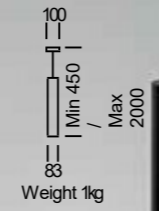

Weight 1kg
 1x GU10 7W LED 2700K
 CE U L IP20
 See pages 60-64 for full range.



The pendants illustrated here are selected from elsewhere in the catalogue and are part of matching ranges – see page referrals for further details.

TY 10P

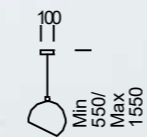

Weight: 1.6kg
 1x E27 6W LED 2200K
 CE U L IP20
 See pages 58-59 for full range.

TY 10P with optional shade QTY/P/ OY

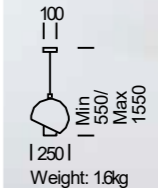

Weight: 1.6kg
 1x E27 7W LED 2700K
 CE U L IP20
 See pages 58-59 for full range.



The pendants illustrated on these pages are selected from elsewhere in the catalogue and are part of matching ranges – see page referrals for further details.

Materials: Duplex glass for DN/20 models, steel for DN/125/C and DN/35/BL, fabric for PE/60.

Finishes: DN/20/W – Opal. DN/20/BL – Black/Opal. DN/35/BL – Black/White. DN/125/C – Chrome/White. PE/60/BL/COP – Black/Copper.

Features: Supplied with Polished Chrome suspension units except for PE/60/BL/COP which is Brushed Nickel.



SE 14/F/C



100
Min 250/Max 2000
300

LED 6W 2700K
CE UL IP20
(Requires modification for UL.)
See pages 77-79 for full range.



MH/2/P/BRB



100
Min 200/Max 2000
90
Weight 1kg

LED 5W 2700K
CE UL IP20
(Requires modification for UL.)
See pages 82-83 for full range.



DN/20/W



Min 500/Max 2500
200
Weight 2kg



DN/20/BL

1x E27 7W LED 2700K
CE UL IP20

In addition to downlighting this model also gives soft diffused general light.



PE/60/BL/COP



Min 600/Max 1600
300

1x E27 7W LED 2700K
CE UL IP20



MD/8/P with optional shade QMD/P/SM



100
Min 330/Max 2000
160
Weight 0.2kg

1x E27 3W LED 2200K
CE UL IP20
See pages 45-47 for full range.



BX/44/P



600/Max 1400
200

1x E27 3W LED 2200K
CE UL IP20
See pages 132-133 for full range.



DN/35/BL



Min 500/Max 2380
350
Weight 1.5kg

1x E27 7W LED 2700K
CE UL IP20

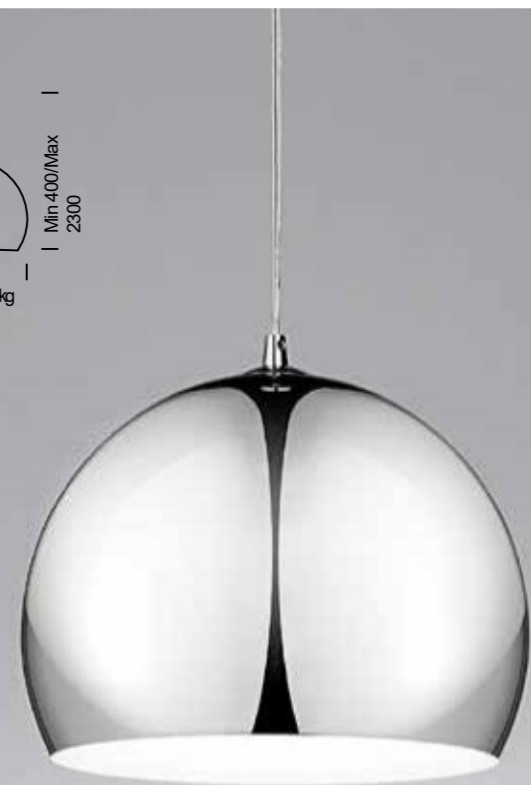

DN/125/C

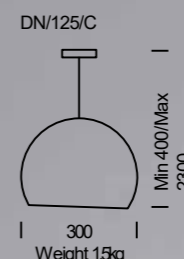

Min 400/Max 2300
300
Weight 1.5kg

1x E27 7W LED 2700K
CE UL IP20

Material: Steel.
Finish: Satin Black with Gold accents.

Features: Two flat horizontal rings with recessed contrasting colour centre section are suspended from three fine strainer wires. Black fabric cylinder shades with steep angled cuts have Champagne Gold interiors to give a warm ambient glow of gold uplight. This highly decorative fitting can be made in any finish, diameter or shape with any number of lights or tiers. Please contact Chelsom with your ideas and concepts.

CS/ 8 / 12 with optional shades QCS/BG

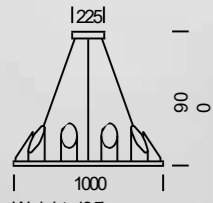

Weight: 13.5kg

12x LED 1W 2700K

CE \neq IP20

(Needs modification for UL)



Project : CUSTOM CROWN at
The Grand Hotel, Lytham St. Annes.
Designer: In-house Design Team.



Project : CUSTOM CROWN at
The Grand Hotel, Lytham St. Annes.
Designer: In-house Design Team.

Copyright 2018 Chelsom Ltd

CUSTOM
FLARE

Material: Steel.

Finish: Satin Black.

Features: Vertical tubular columns flare out from a central ring. Finish, number and arrangement of arms and diameter of chandeliers to be specified. Shown with Black shades and Copper interiors, other fabrics can be chosen from pages at the back of the catalogue. Shade shapes can be a random selection as shown in the render. Please contact Chelsom with your ideas and concepts.

FE/60/8 with optional shades QSR/6/BL/COP

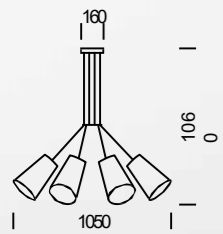

Weight: 5kg

8 x E27 7W LED 2700K
CE U_L IP20



CUSTOM
DIAMOND

Material: Steel.

Finish: Satin Black.

Features: A strong geometric diamond frame suspends Black chintz cylinder shades with a Gold Herringbone pattern inside to give a warm and decorative ambient glow. Alternative finishes, larger sizes, different shapes and shade options available. Please contact Chelsom with your ideas and concepts.



DM/87/6 with optional shades QCY/14/BL/GHB

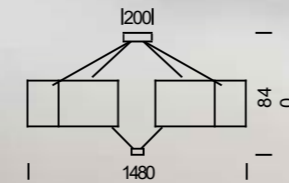

Weight: 13kg

6 x E27 7W LED 2700K
CE U_L IP20



Copyright 2018 Chelsom Ltd

CUSTOM
RODS

Materials:
Steel and
acrylic.

Finishes: Metal – Off
White and Brushed
Nickel for single pendant.

Features: A lighting concept allowing clients to create their own custom designs in any finish and virtually any shape, size or number of tiers can be created (see installations below). Rods are screwed into the metalwork.

Each rod is illuminated from above with a warm white LED light source which sparkles at the bottom of the rod and through the bubbles inside where applicable. Individual rod pendants are also available as are fixed suspension versions. Various rod diameters and lengths are available. Please contact Chelsom with your ideas and concepts.

CUSTOM
RODS



Project: CUSTOM RODS at Crowne Plaza Reading.
Designer: ADS Design.



Project: CUSTOM RODS on board MS EUROPA 2.
Designer: Partnership Design.

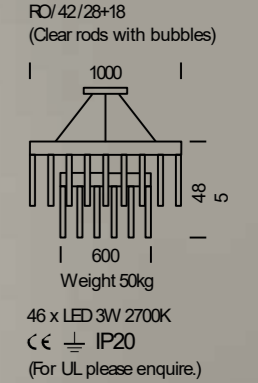
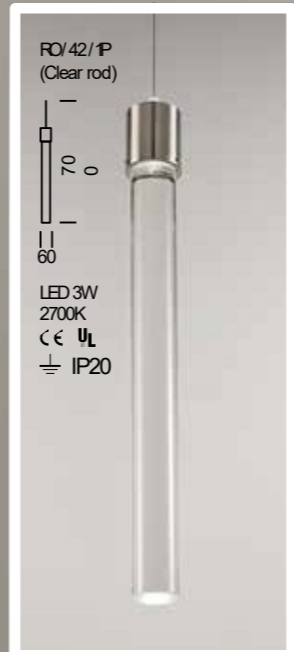

Copyright 2018 Chelsom Ltd

Project: CUSTOM FILAMENT at Mercure Bristol North The Grange Hotel.
Designer: Helen Hooper Interiors.



FI/41/16+8 with optional filament lamps (please enquire)

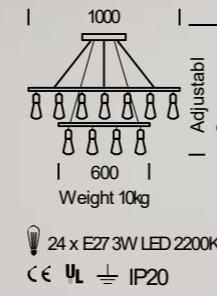

Project: CUSTOM FILAMENT at Castle Hotel Windsor – MGallery by Sofitel.
Designer: Trevillion Interiors.



Copyright 2018 Chelsom Ltd



Laser cut perimeter pattern



Laser cut geometric pattern

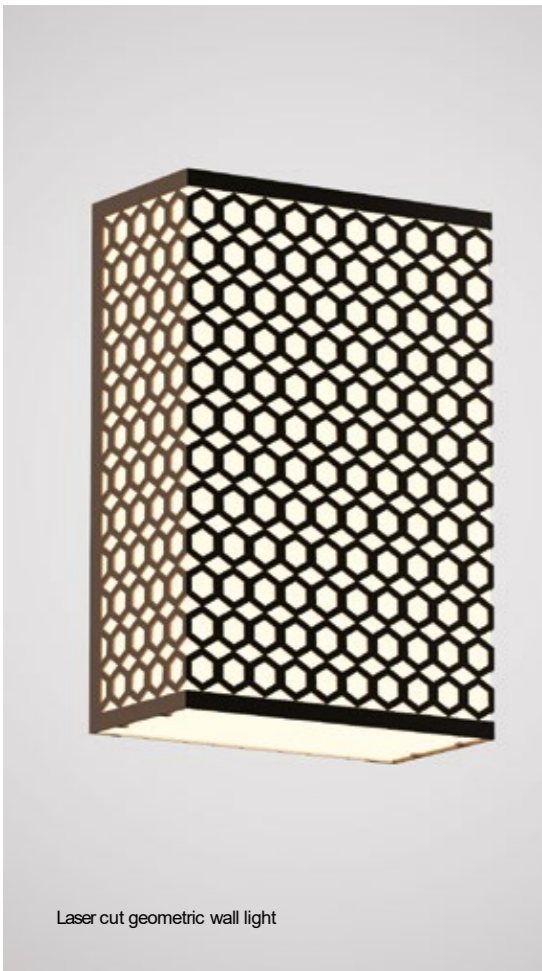

Laser cut geometric wall light



Laser cut random rings wall light



Laser cut logo wall light



LA/40/P/1000
Adjustabl
1000
Overall minimum height 770
Weight 17kg
8 x E27 7W LED 2700K
CE U_L IP20



LA/40/ W1/300x200
200 | 30 | 1100
1x E27 7W LED 2700K
CE U_L IP20
Laser cut random
lines wall light

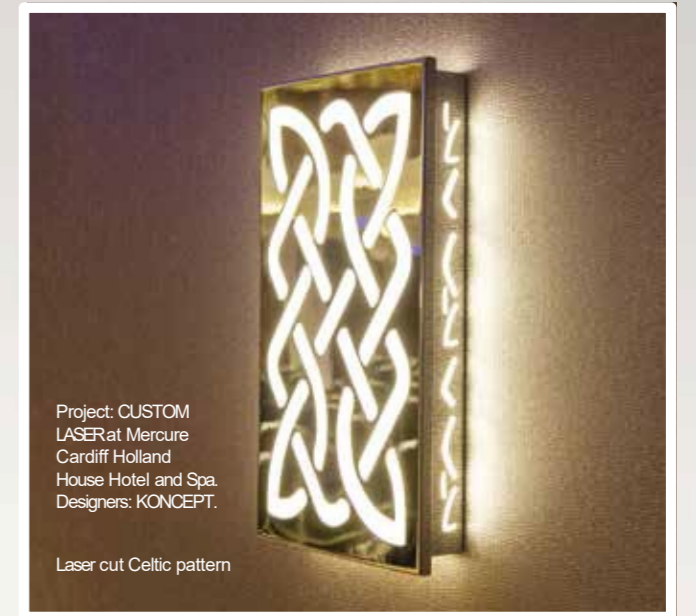

Project: CUSTOM
LASER at Mercure
Cardiff Holland
House Hotel and Spa.
Designers: KONCEPT.
Laser cut Celtic pattern

GX/102/600/ 18

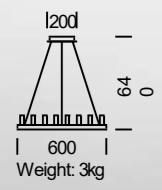

LED 25W 2700K
CE \neq IP20
(For UL please enquire.)



Custom shapes to special order

GX/102/1000/ 30+24+18

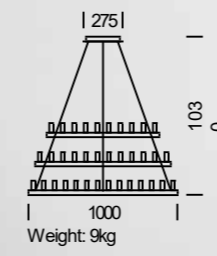

LED 100W 2700K
CE \neq IP20
(For UL please enquire.)



TEARDROP

Materials: Steel and glass.
 Finish: Polished Nickel with frosted glass diffuser.

downlight. Small ventilation holes allow light spill and heat escape. Available as standard with three pendants on a ceiling plate or as an individual unit, the range can be adapted for multi pendant use as shown opposite.

Project: TEARDROP at St. Martins Lane London.
 Designer: Banjo Ad Inc.



Teardrops shown in a multi pendant formation



TD/3/3P

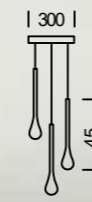

Height adjustable
 3 x LED 8W 2700K
 CE IP20
 (For UL please enquire.)



TD/3/P

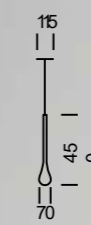

Height adjustable
 LED 8W 2700K
 CE IP20
 (For UL please enquire.)

Copyright 2018 Chelsom Ltd

Material:
Hand forged
iron.

Finish:
Florentine Antique
Silver Leaf.

Shades: Spring clip
candle shades available
— see back of catalogue.

See overleaf
for further
design options.

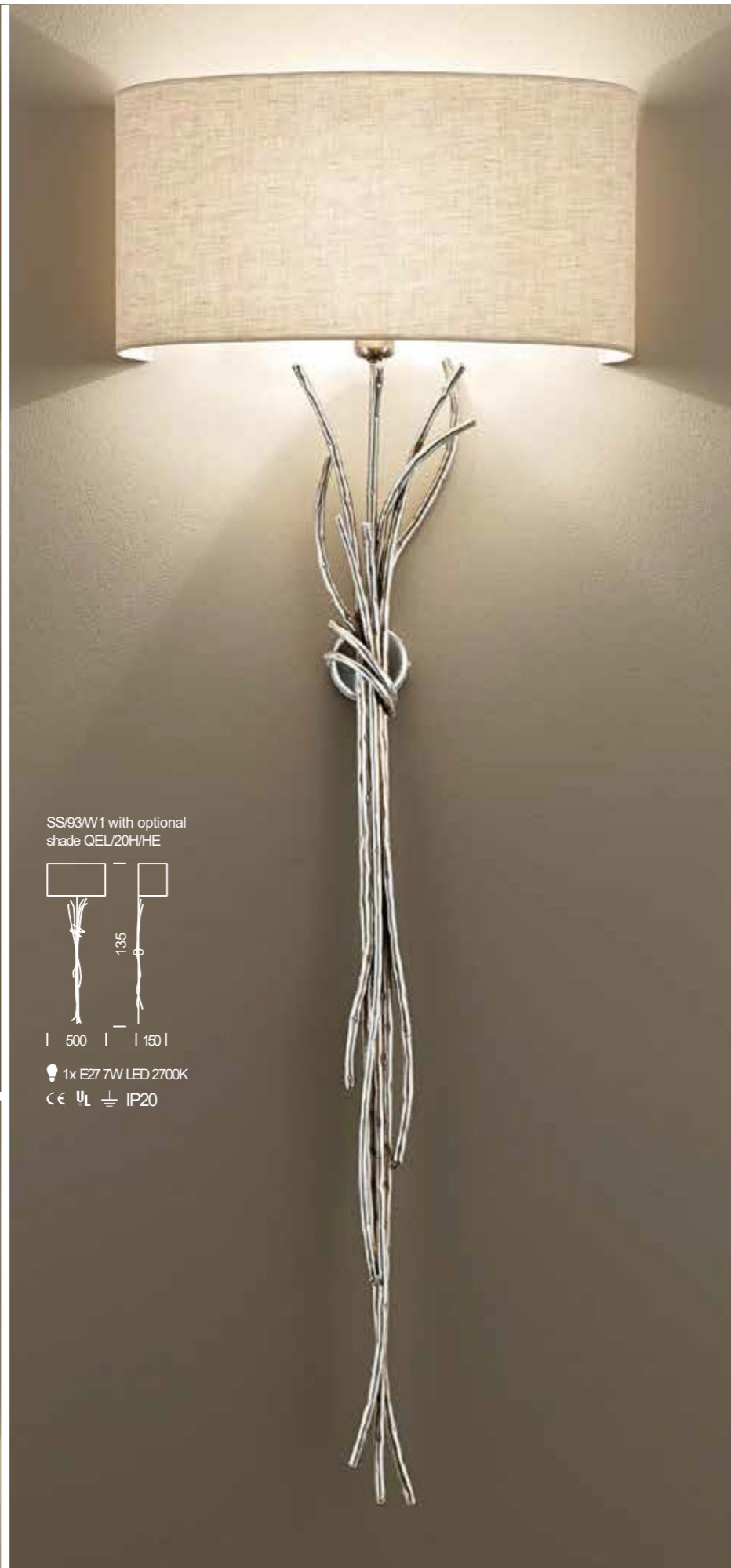

SS/90/6+3 with optional
shades QCO/6/SC/HE

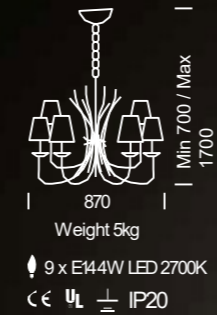

SS/90/8+4



SILVER SCULPTURE

Material:
Hand forged
iron.

Finish:
Florentine Antique
Silver Leaf.

Features: For SS/21/SI/VPL
price and dimensions
include shade shown.

Shades: Pendant SS/21/SI is shown with a pleated Ivory shade (MPL).
Other plain fabrics available (please enquire). Pendant shades have
parchment bottom diffusers. See back of catalogue for optional shades.

See previous
pages for further
design options.

SILVER SCULPTURE



SS/21/SI/VPL



SS/80/4P



SS/12W1 with optional
shade QBR/ 10H/LINEN ST

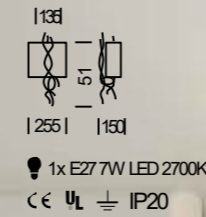

SS/13W1 with optional
shade QBR/ 14H/LINEN ST

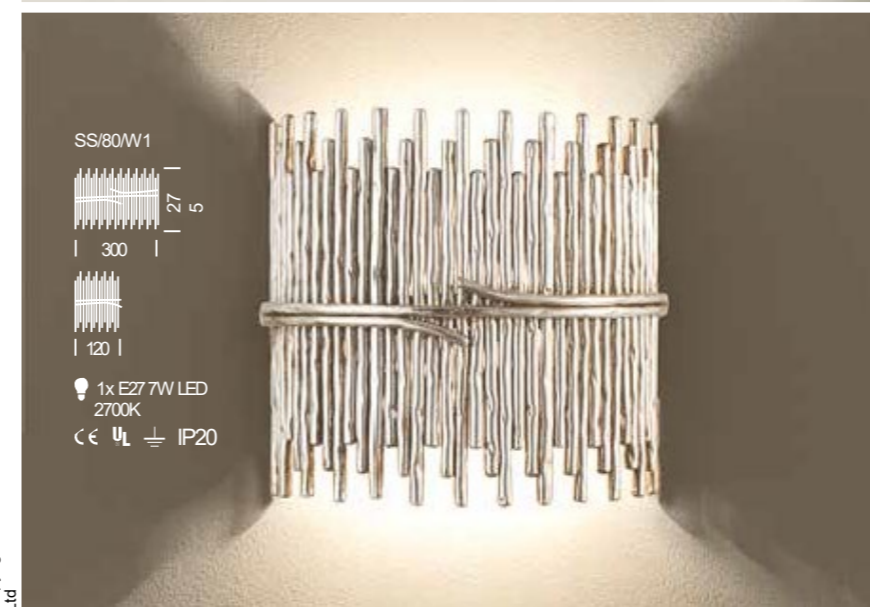
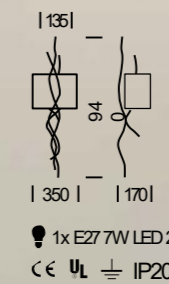

SS/80W1



SS/90/FS
see page 194



SS/90/TL
see page 194

Material: Steel.

Finish: Florentine Antique Gold Leaf.

Features: Hand-formed and decorated metal palm leaves allow light to emit through pierced slots as well as giving a warm glow of back light for a highly ambient collection.

PM/28/W2

| 315 | | 190 |

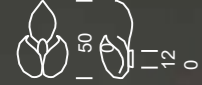

ψ 2 x E14 3.5W LED 2100K

CE U_L IP20



PM/28/800/P from below

PM/28/800/P

| 800 |



Weight 6kg

ψ 6 x E14 3.5W LED 2100K

CE U_L IP20

PM/28/650/P

| 650 |

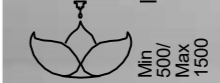

Weight 4.5kg

ψ 6 x E14 3.5W LED 2100K

CE U_L IP20



Copyright 2018 Chelsom Ltd

Materials:
Wrought iron
and steel.

Finish: Florentine
Antique Gold
Leaf.

Features: Random curved
metal leaves with internal gold
leaf to reflect warm glow.



Copyright 2018 Chelsom Ltd

Materials: Steel
(frosted glass diffuser
for GG/14/P).

Finish:
Penny
Bronze.

Shades: Shades on this page are
Oyster with Taupe trim (OYT). See
back of catalogue for optional shades.



Project: GLASGOW at The Farmers Club, London.
Designers: Helen Hughes Design.
Photography by Adam Woodward Photography.



GG/14/10 with optional
shades QGG/8/OYT
10 x E27 7W LED 2700K
CE UL IP20

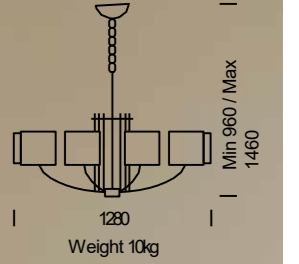

GG/14/6 with optional
shades QCY/6/E27 OY
6 x E27 7W LED 2700K
CE UL IP20

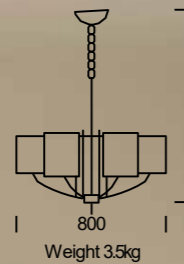

GG/14/P with optional
shade QCY/GGP/NU
3 x E27 7W LED 2700K
CE UL IP20

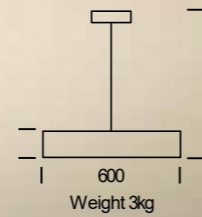

GG/14/W2 with optional
shades QGG/8/OYT
2 x E27 7W LED 2700K
CE UL IP20



GG/14/W1 with optional
shade QGG/8/OYT
1 x E27 7W LED 2700K
CE UL IP20

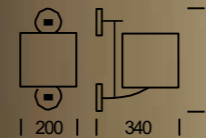

GG/14/10+5 with optional
shades QGG/8/OYT
15 x E27 7W LED 2700K
CE UL IP20

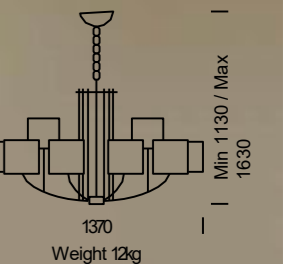

Copyright 2018 Chelsom Ltd

Materials: Cast brass and steel. Finish: Polished Chrome. Shades: See back of catalogue for optional shades.



Copyright 2018 Chelsom Ltd

Project: AILSA at Swissôtel The Bosphorus, Istanbul.
Designers: KCA International.



Materials: Steel with cottonette fabric.

Finish: Penny Bronze with Oyster fabric diffusers.

Features: Opal acrylic top diffusers prevent dust and insect ingress and lift out for cleaning and maintenance.

AI/55/1200/P

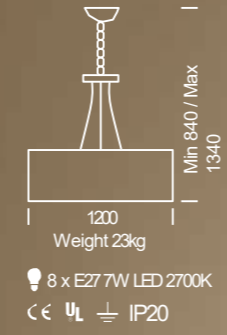

AI/55/600/P

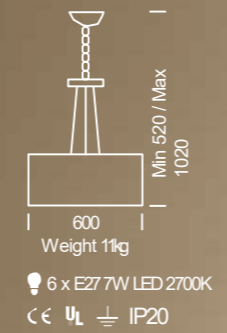

Copyright 2018 Chelsom Ltd

Materials: Steel frames with acrylic diffusers.

Finish: Steel Grey painted metalwork with Opal acrylic.

Features: High light output from architectural fittings to illuminate public spaces. Options available include special sizes, dimming, integral emergency lighting, mesh covers for open bowls to prevent dust and insect ingress and special metal colour finishes.

SA/28/900/P

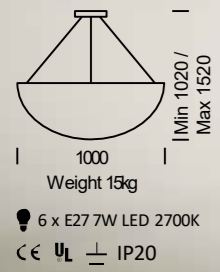

SA/28/900/F

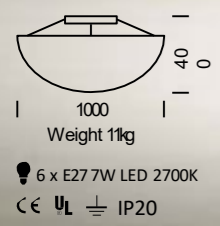

SA/29/600/P

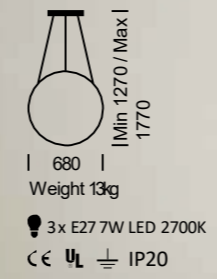

Steel and fabric.

with fabric shades – see back of catalogue for fabric options.

down the outside of the shades. The large pendant has an internal bottom self-fabric diffuser. Other finishes, sizes and shapes to special order.

Materials: Steel frames with various fabric options.

Finishes: Suspension metalwork in Polished Chrome, Brushed Nickel or paint finish.

Features: Chelsom offer a vast selection of handmade pendant shades in fabrics, designs and dimensions to suit clients' requirements. Standard designs are shown below with a selection of recent custom installations on the following two pages.

WELCOME



Copyright 2018 Chelsom Ltd

Large scale shades in a variety of shapes, fabrics and designs help to create maximum impact in public spaces for the hospitality and marine industries.

We have expertise in fabric selection, lamp options, light output, suspension systems, packing and delivery of feature pendant shades. Adjustable suspension wires allow for varied ceiling heights and most shades have top diffusers to prevent dust and insect ingress.

Materials: Steel frames with fabric diffusers.

Finish: Natural fabric with Oyster bottom diffusers on pendants.

Features: Fabric shades 'snap on' to backplates or ceiling plates for ease of installation and maintenance.



Project: WELCOME SHADES at TWENTY EIGHT, Amsterdam.
Designer: Martin Brudnizki Design Studio.



Project: WELCOME SHADES at Malmaison Edinburgh.
Designer: Curious.



Copyright 2018 Chelsom Ltd

Materials: Steel and glass.

Finish: Metalwork is finished in Black Bronze with English Brass accents. Glass is Smoke.

Features: Heavy circular glasses have deep concentric rebates creating a light effect of ripples on a pond. Wall lights also give a decorative spill of light onto walls. All models are dimmable, wall lights remotely and table lamp with knurled rotary switch.

SL/11W1

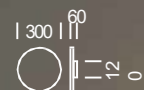

LED 6W 2700K
CE \neq IP20
(For UL please enquire.)



SL/12TL



LED 6W 2700K
CE \neq IP20
(For UL please enquire.)



SL/12W1

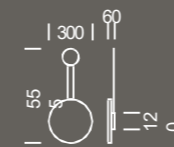

LED 6W 2700K
CE \neq IP20
(For UL please enquire.)

SL/12W1



REFLECTOR

Material: Steel.
 Finishes: Brushed Brass with Satin Black (BRB) or Satin Copper with Satin Black (COP SAT).

Features: Warm white LED light in the central housing glows back off the faceted reflector plate. The wall light is available in two sizes and can also be used as a flush mounted ceiling fitting.

RR 30' W1/COP SAT (wall mounted)

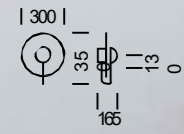

LED 8W 2700K
 CE U_L IP20



RR 30' W1/COP SAT (ceiling mounted)



RR 30' W1/BRB (wall mounted)

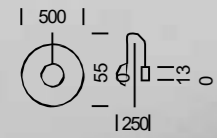

LED 8W 2700K
 CE U_L IP20



RR 30' W1/BRB (ceiling mounted)



REFLECTOR

Project: REFLECTOR at DoubleTree by Hilton Hotel Glasgow Central.
 Designer: Cunningham McLean.

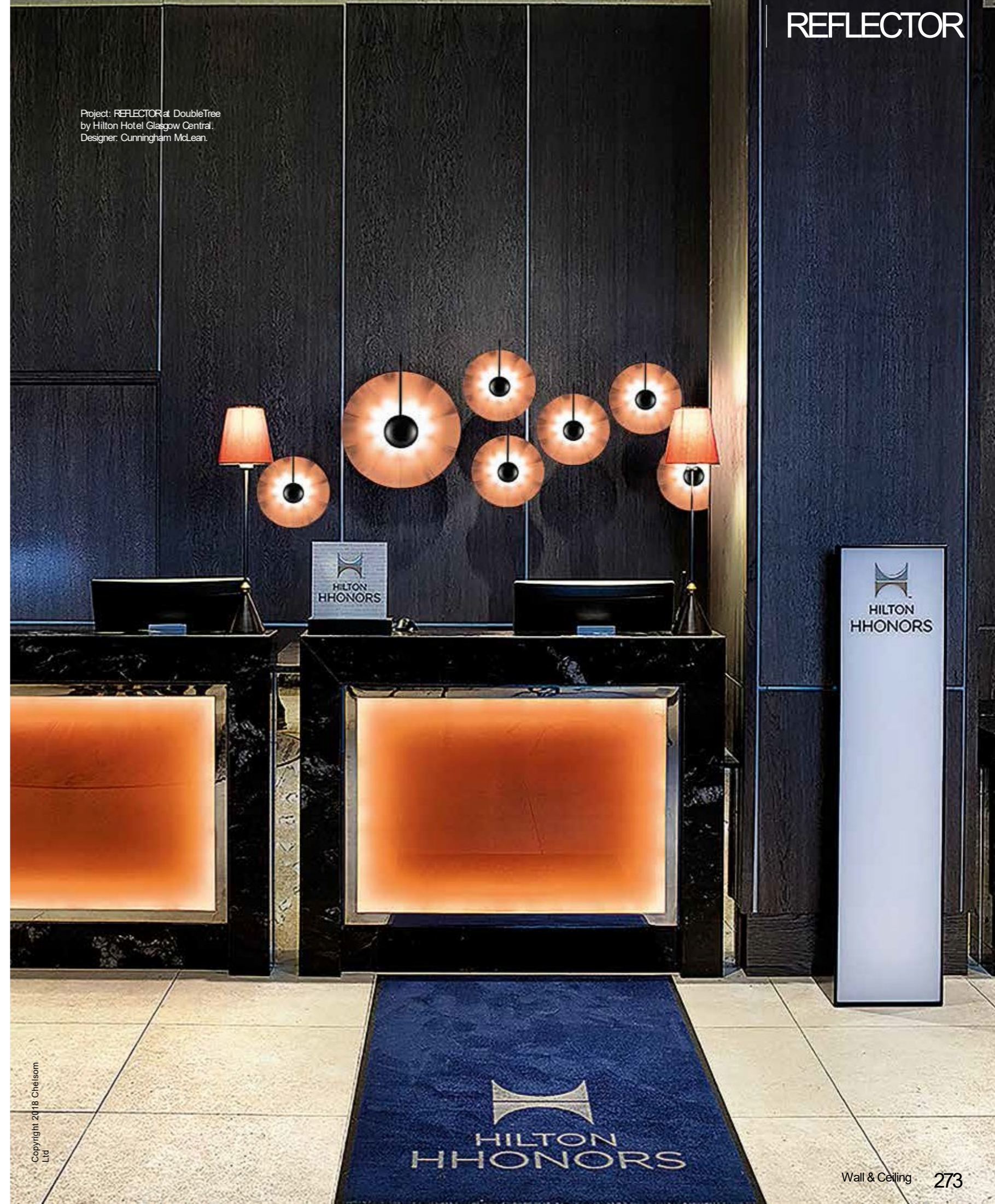

Copyright 2018 Chelsom Ltd

Materials: Steel metalwork with various fabric options.

Finish: Satin Black (BL) metalwork.

Features: Shade shape creates striking light effect up and down plus reflected light. Shades shown are Black chintz with Brushed Copper lining (BL/COP) or Natural (NAT). Other shade fabrics to special order.

Project : SCONCE at The Grand Hotel, Lytham St. Annes.
Designer: In-house Design Team.



Material: Steel.

Finishes: Brushed Brass (BRB) or Black Bronze (BB).

Features: Slender elliptical tubes have concealed LED backlight giving a glow of light onto walls. LED drivers are integral within the backbox.

HO/3W1/BB

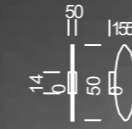

LED 12W 2700K
CE UL IP20
(For UL please enquire.)



HO/3W1/BRB

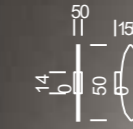

LED 12W 2700K
CE UL IP20
(For UL please enquire.)



FEATURE WALL LIGHTS

Feature Wall Lights shown here and on the following pages brings together a selection of wall lighting from the catalogue with design features or proportions that make them important pieces for public area or guestroom interior design schemes. There is a referral to the relevant page numbers within the catalogue.

FEATURE WALL LIGHTS



Copyright 2018 Chelsom Ltd

FEATURE WALL LIGHTS

Materials (SO/34/W1):
Aluminium and steel.

Finish (SO/34/W1):
Polished aluminium with Satin Black.

Features (SO/34/W1): Art Deco design with deep vertical ribbing and Satin Black metal shade.

Feature Wall Lights brings together a selection of wall lighting from the catalogue with design features or proportions that make them important pieces for public area or guestroom interior design schemes.

FEATURE WALL LIGHTS



Copyright 2018 Chelsom Ltd

FEATURE WALL LIGHTS

Materials: Steel with glass on PB/4/W1 and GD/59/W1. Frosted polycarbonate on PB/70/W1/BN and Chocolate wood on PB/10/W1.

Finishes: Polished Chrome below with Brushed Nickel opposite for PB/70/W1/BN and PB/50/BN. SS/80/W1 Florentine Antique Silver Leaf.

Features: Public area wall lighting. PB/50/BN gives up and down light. GD/59/W1 features individual clear glass rods. Shade options at back of catalogue.

FEATURE WALL LIGHTS



Copyright 2018 Chelsom Ltd

deer antlers
(naturally
shed every year).

Natural
antler.

piece is unique with slight variations in
shape,
colour and dimensions. Hemp shades
shown.

HI/595/8 with optional
shades QST/6/E14/HE

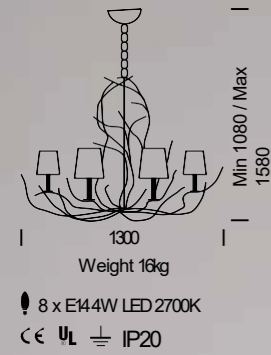

HI/591/6 with optional
shades QST/5/E14/HE

6 x E144W LED 2700K
CE U_L IP20

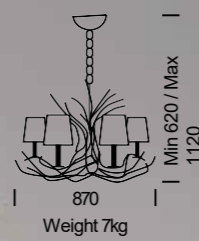

HI/135/W1 with optional
shade QST/6/E14/HE

1x E144W LED 2700K
CE U_L IP20

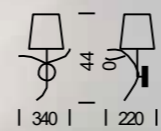

Material: Solid cast brass.
Finishes: Antique Bronze or Polished Nickel.
Shades: See back of catalogue for optional shades.



BS/3/W1 with optional
shade QEL/14/HE

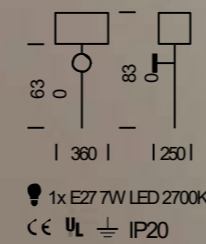

SS/3/W1 with optional
shade QTC/6/E27/BS

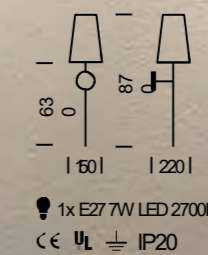

CLASSIC PICTURE LIGHTS

Material: Steel.

Finishes: English Brass (EBR) or Black Bronze (BB).

Features: Detailed backplates and swan neck arms with swivel joints support tubular canopies with anti-glare baffles on the front.

PL/8/300/EBR

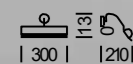

1x E14 4W LED 2700K
CE U_L IP20



PL/8/550/BB

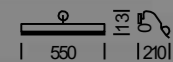

2x E14 4W LED 2700K
CE U_L IP20



PICTURE LIGHTS

Materials: Steel with acrylic diffuser.

Finishes: Black Bronze (BB) or Polished Chrome (C).

Features: Adjustable slim head with front baffle to prevent glare. Warm white integral LED with frosted diffuser for good light output. Dimming options available for minimum order quantities.

PL/6/300/C

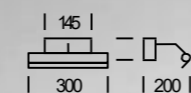

LED 6W 2700K Non-dimmable
CE U_L IP20
(For UL, please enquire.)



PL/6/550/BB

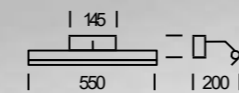

LED 12W 2700K Non-dimmable
CE U_L IP20
(For UL, please enquire.)



Copyright 2018 Chelsom Ltd

Glass and steel.

metalwork with Clear glass.

Frosted glass underneath diffuses the light source. Steel suspension wires can be adjusted during installation. Clear LED lamps recommended. Custom sizes available up to 1200mm diameter.

Materials: Solid brass and clear glass.

Finishes: Polished Nickel (PN) or Polished Brass (PB).

Pricing: Metalwork and glass are priced separately.

Features: Clear LED candle lamps recommended.

KENSINGTON LANTERNS

SP/32/800



Project: SPARKLE at Malmison Newcastle.
Designer: Curious.



SP/32/500

6 x E14 3.5W LED 2100K
CE U_L IP20



SP/32/W2

2 x E14 3.5W LED 2100K
CE U_L IP20

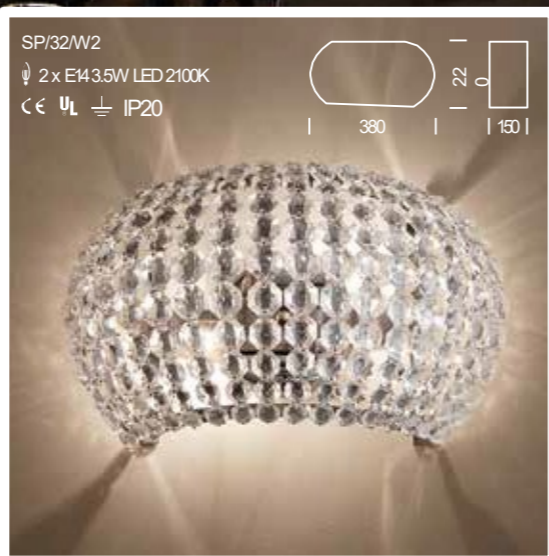

KL/100/3/PN - Polished Nickel with glass KL/100/GS

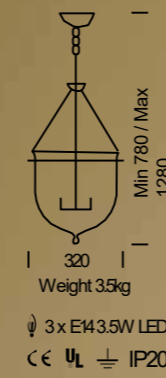

KL/100/6/PB - Polished Brass with glass KL/150/GS

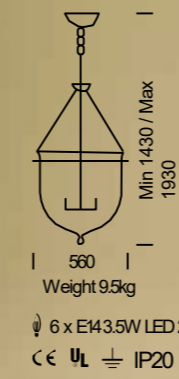

Copyright 2018 Chelsom Ltd



Materials: Solid brass,
clear glass (frosted
glass on request).

Finishes: Polished
Nickel (PN) or subtle
Antique Brass (AB).

Features: Clear LED candle lamps
recommended except where optional
shades are fitted (MY/122/L/PN).



Copyright 2018 Chelsom Ltd

Solid cast brass. Bronze. LED candle lamps recommended.

TECHNICAL REFERENCE



PRODUCT TECHNICAL SPECIFICATIONS

Every product included in the Edition 26 catalogue is shown with basic dimensions and technical specification. For full technical specification details please visit the Chelsom website www.chelsom.co.uk from where Product Specification Sheets can be downloaded.

TECHNICAL SPECIFICATION KEY

The following symbols or technical comments appear throughout Edition 26.

CE CE Symbol (Conformité Européenne) Denotes compliance with relevant European electrical safety regulations.

UL UL Symbol (Underwriters Laboratory) Denotes compliance with relevant USA and Canadian electrical safety regulations for lighting products.

I Class I Symbol Denotes the electrical safety class of the product – earth included.

□ Class II Symbol Denotes the electrical safety class of the product – double insulated.

IP20 IP20 (Ingress Protection) Denotes protection against dust or water ingress – normal internal use excluding bathrooms.

IP44 IP44 (Ingress Protection) Denotes protection against dust or water ingress – normal bathroom use.

IP65 IP65 (Ingress Protection) Denotes protection against dust or water ingress – shower/bath area use or outdoors.

ZONE 1 Zone 1 in Bathrooms The area above that defined by the perimeter of the bath or shower tray.

ZONE 2 Zone 2 in Bathrooms The area adjoining the bath or shower tray up to a distance of 600mm.

2700K 2700K Colour Temperature Denotes colour temperature measured in Kelvins (2200K to 3000K within the standard range).

USB USB Symbol Denotes product which comes with integral USB charging port with 2.0A output.

INTERNATIONAL ELECTRICAL STANDARDS

Chelsom can wire in-house to meet all international standards. Luminaires are constructed and tested to comply with the Electrical Equipment (Safety) Regulations 1994 with reference to ESEN 60598 – 12015 and with the applicable ESEN 60598 Part 2 standard. Most of the range has UL approval and almost all luminaires can be wired for 110V or 230V.

LIGHT CALCULATIONS

The experienced Chelsom consultants are pleased to visit site and discuss lighting schemes and light calculations with clients. Either lux level readings can be taken on site or calculations can be made at Head Office from architects' drawings and plans. Advice can be given on the location, quantity and type of light sources required.

EMERGENCY LIGHTING

Whether emergency lighting is required within individual luminaires or is installed remotely, Chelsom are knowledgeable in all aspects of emergency lighting requirements. Please contact the Technical Team to discuss legal requirements and how those standards might be met with Chelsom lighting.

TRADE ASSOCIATION MEMBERSHIPS

CABLE AND PLUGS

Cable colour will be selected to complement the finish of the luminaire. Portable luminaires will normally have 2 metres cable length from the base to a 13amp UK plug (fused 3 amp). 5 amp plugs and many international plugs are available.

PENDANT LUMINAIRES

Pendants are normally supplied with 2000mm of suspension chain or cable and all have ceiling plates. Refer to the website for full technical specifications and installation instructions. To facilitate maintenance of larger pendants in high-ceilinged rooms, we can advise upon and arrange installation of manual or power winches.

DIMENSIONS AND WEIGHTS

Minimum heights shown for pendants include one link of chain, where applicable, and the ceiling plate. Maximum heights include the above plus the normal amount of chain supplied (extra lengths available on request). Weights for pendants are shown and include glass where illustrated. Portable luminaire base only heights are measured including lampholder cover and heights with shade relate to the shade illustrated. Projection is the maximum distance any part of a wall light extends from the wall including shade if shown.



Project: CLASSIC EXTERIOR at Blue Waters Antigua.
Designers: In-house Design team.

Pages 292-295 illustrate the standard Chelsom shade collection showing technical information and fabrics available. Other individual or range specific shades are shown throughout the catalogue and we welcome enquiries for any special shapes, designs or fabrics. Shades are handmade with white epoxy coated three or four strut frames (gold struts when shades have gold lining) and have E27 fixed gimbal as standard.

E14 or spring clip fixings are also available (denoted by model number if standard). Snap-in converter rings are available to change E27 to E14/B22/B15. Wipeable shade fabric is available in White or Off White. Maximum recommended lamp wattages are shown within line drawings.

*Please add colour suffix when ordering (see overleaf).

QST – SHALLOW TAPERED with frosted acrylic top diffuser with ventilation hole

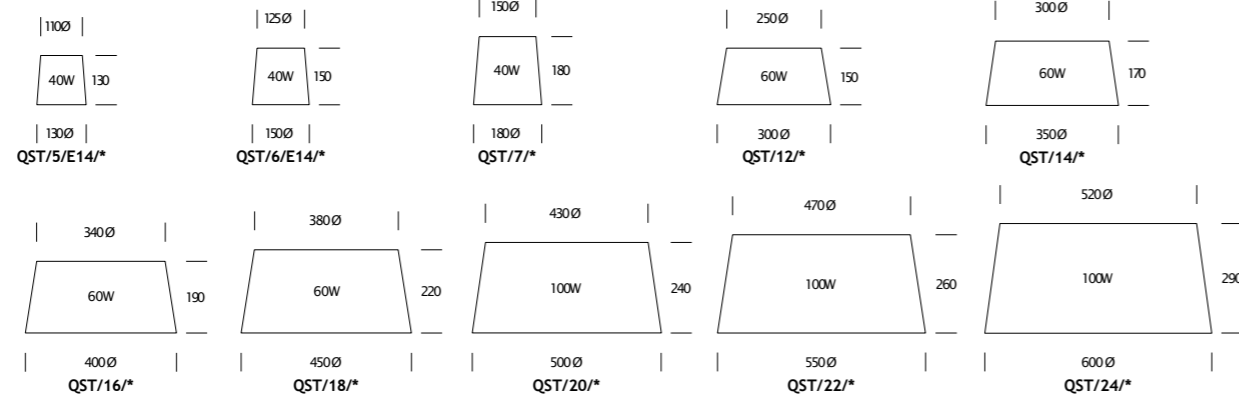

QBR – BOWED RECTANGLE

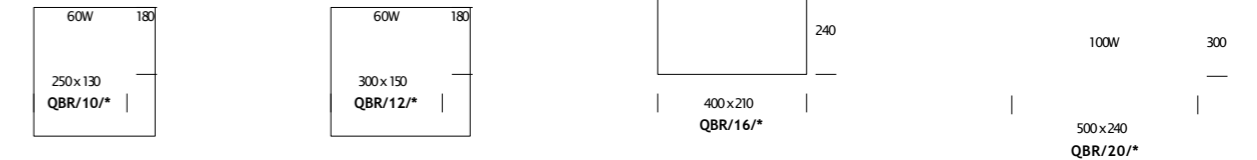

QFD – FRENCH DRUM

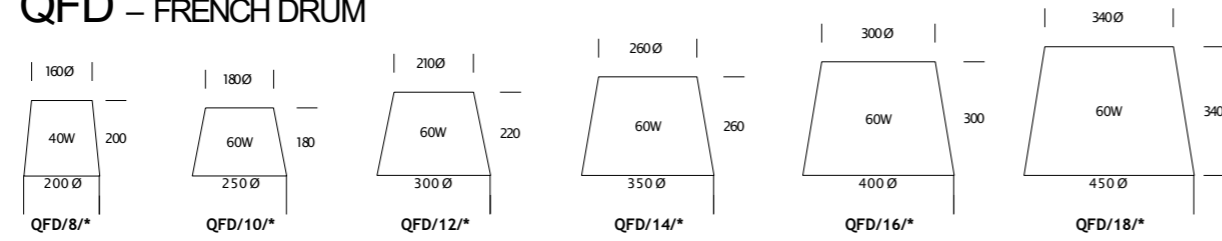

QKE – KNIFE PLEAT EMPIRE (WRAPPED PLEAT)

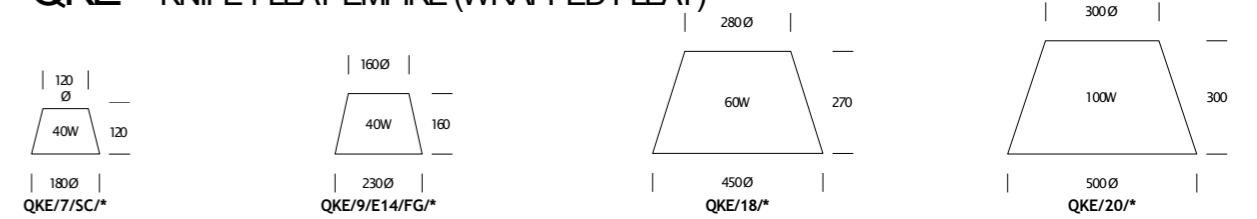

QCY – CYLINDER

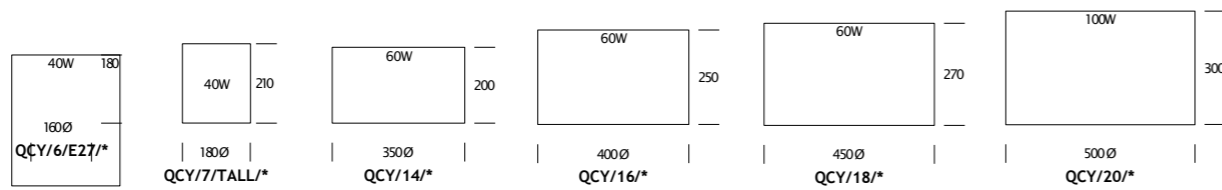

QOB – OBLONG

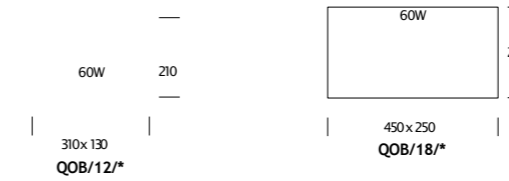

QRTS – ROUNDED TAPERED SQUARE

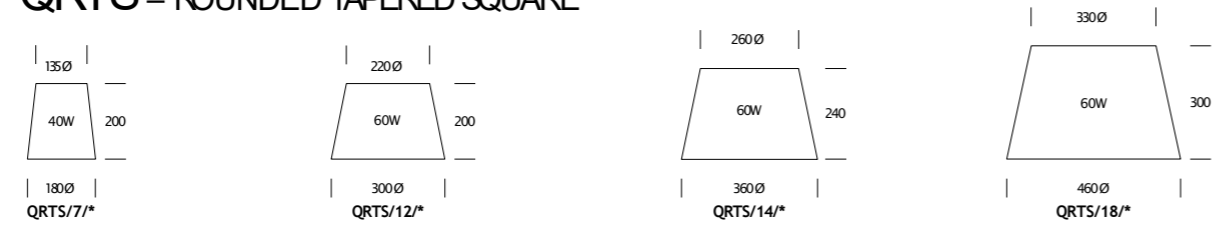

QTC – TALL CONE

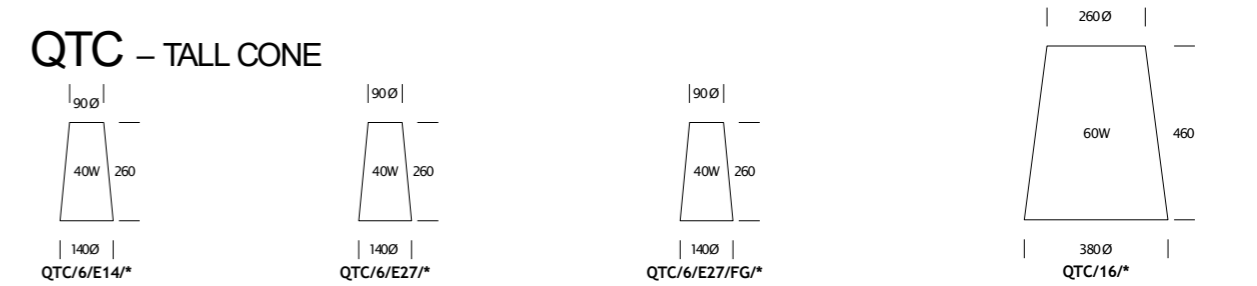

QEL – ELLIPSE

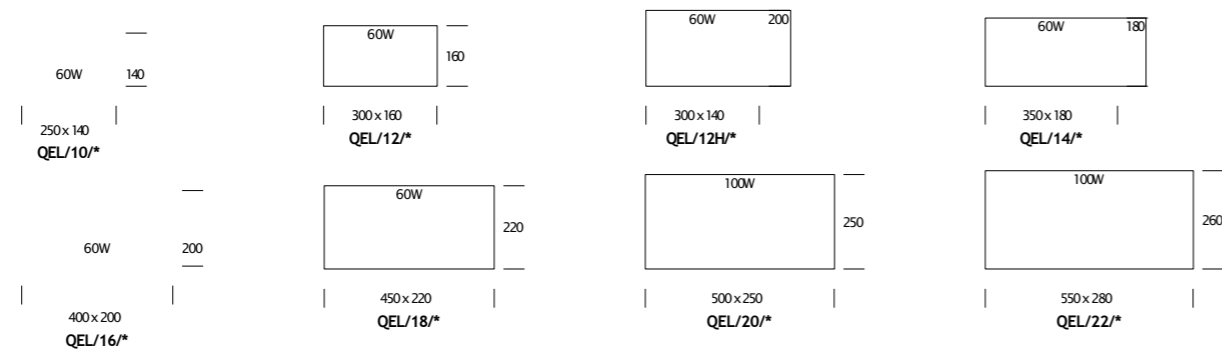

Copyright 2018 Chelsom Ltd

SHADE FABRIC OPTIONS



Cotton Chintz Oyster
(OY)



Cotton Chintz White
(W)



Cotton Chintz Stone
(ST)



Cotton Chintz Black
(BL)



Cotton Chintz Gunmetal
(GM)



Cotton Chintz Pebble
(PEBBLE)

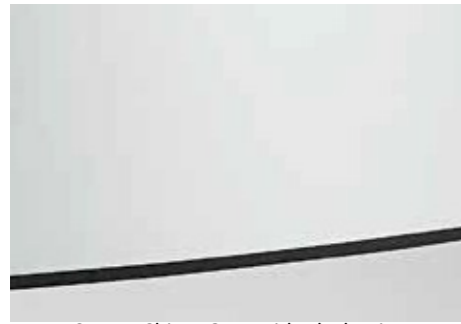

Cotton Chintz Grey with Black Trim
(GRB)



Cotton Chintz Oyster with Grey Trim (OYG)
Also Oyster with Black (OYB) & Oyster with Taupe (OYT)

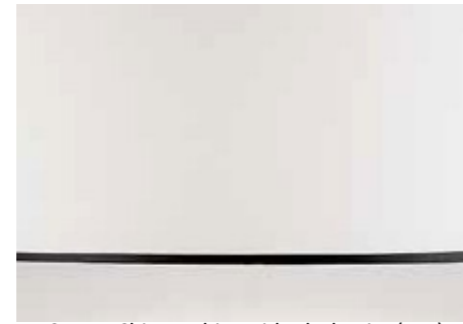

Cotton Chintz White with Black Trim (WB)
Also White with Grey Trim (WG)



Cotton Chintz White with Gold Lining
(WGO)



Linen Aubergine
(LINEN AUB)



Linen Natural
(LINEN NAT)



Linen Bone
(LINEN BONE)



Linen Stone
(LINEN ST)



Hemp
(HE)

OTHER FABRICS AVAILABLE TO SPECIAL ORDER

SHADE FABRIC OPTIONS



Natural
(NAT)



Pongee Silk Putty
(SILK PUTTY)



Pongee Silk Thimble
(SILK THIMBLE)



Pongee Silk Pebble
(SILK PEBBLE)



Pongee Silk Kelp
(SILK KELP)

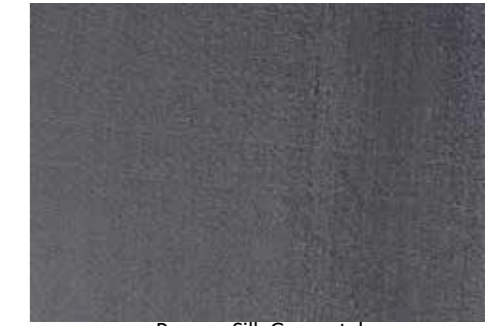

Pongee Silk Gunmetal
(SILK GM)



Pongee Silk Meadow
(SILK MEADOW)



Pongee Silk Herb
(SILK HERB)



Ivory Pleat
(IVPL)



Black with Gold Lining
(BG)



Black with Silver Lining
(BS)



Black with Copper Lining
(BL/COP)

OTHER FABRICS AVAILABLE TO SPECIAL ORDER

Model No.	Page	Model No.	Page	Model No.	Page	Model No.	Page	Model No.	Page
AC/ 79/ 12	256	BC/ 10/ FS	80	BW/ 327	64	CL/ 15/ W1 LED* *	37	DL/ 4/ USB/ C	124
AC/ 79/ 3	256	BC/ 10/ TL	81	BW/ 6	66	CN/ 12083/ AB/ EZ	195	DL/ 41* *	16-117
AC/ 79/ 9	256	BC/ 10/ W1	80	BX/ 44/ FS	132	CO/ 9/ *	190	DM/ 87/ 6	239
AC/ 79/ W2	256	BE/ 68/ FS/ *	129	BX/ 44/ P	132/ 234	CF/ 24/ 4/ *	44/ 221	DN/ 125/ C	235
AD/ 35/ FF	218	BE/ 68/ TL/ *	128	BX/ 44/ TL	133	CF/ 24/ FF* *	44/ 221	DN/ 20/ *	235
AD/ 35/ FF2	219	BE/ 68/ W1* *	129/ 278	BX/ 44/ W1	132/ 278	CF/ 24/ F* *	44/ 221	DN/ 35/ BL	235
AD/ 35/ WW	218	BI/ 22/ DL/ *	90-91	CC/ 110/ FS* *	70-71	CF/ 24/ TL/ *	43	DR/ 8/ W1* *	95
AI/ 55/ 1200/ P	263	BI/ 22/ FL/ *	90	CC/ 110/ TL/ *	73	CF/ 24/ W1* *	42/ 221	DW/ 6/ FS	146
AI/ 55/ 300/ W2	262	BO/ 22/ FS* *	67	CC/ 110/ W1* *	72	CR/ 7/ DL/ BL/ C	121	DW/ 6/ TL	147
AI/ 55/ 450/ F	262	BO/ 22/ TL/ *	65	CE/ 6/ BFB	224	CR/ 7/ DL/ USB/ C	124	DW/ 6/ W1	146
AI/ 55/ 600/ P	263	BO/ 22/ W1* *	66/ 276	CE/ 9/ BFB	224-225	CR/ 7/ FS/ BL/ C	121	DW/ 6/ W1 LED	146
AJ/ 54/ DL/ BB	142	BS/ 3/ W1	283	CH/ 9/ FS/ C	131	CS/ 8/ 12	236	EX/ 5/ DL/ *	139
AJ/ 54/ FS/ BB	143	BW/ 106	64	CH/ 9/ TL/ C	130-131	CT/ 4/ FS	197	EX/ 5/ FS/ C	138
AJ/ 54/ W1 BB	143	BW/ 110/ LED	63	CH/ 9/ W1C	130	CT/ 4/ TL	197	EX/ 5/ FS2/ C	138
AL/ 52/ DL/ *	144	BW/ 112/ LED	67	CH/ 9/ W1 LED/ C	130	CV/ 16/ FS/ C	134	EX/ 5/ TL/ C	139
AL/ 52/ FS/ *	145	BW/ 115/ LED	63	CI/ 35/ F* *	215	CV/ 16/ TL/ C	135	FA/ 30	198
AL/ 52/ W1* *	145	BW/ 115/ LED SS	63	CI/ 35/ SF* *	214	CV/ 16/ W1C	134	FA/ 70	198
AT/ 85/ F* *	226	BW/ 115/ LED	63	CI/ 35/ W2* *	215	CV/ 17/ TL/ C	134	FA/ 80	199
AU/ 22/ P	223	BW/ 168	64	CI/ 36/ W2* *	215	DL/ 12/ *	118-119	FE/ 60/ 8	238
AU/ 22/ WW	223	BW/ 18/ LED	63	CI/ 37/ W2/ C	135	DL/ 15/ BB/ EBR	55	FI/ 4/ 16+8	243
AV/ 60/ FS/ *	152-153	BW/ 20	67	CI/ 38/ SF* *	214	DL/ 19/ EBR	114	GA/ 33/ SM	186
AV/ 60/ TL/ *	152-153	BW/ 22	64	CL/ 15/ FS/ *	37	DL/ 28/ *	122	GA/ 44/ SM	186
AV/ 60/ W1* *	152-153	BW/ 31	66	CL/ 15/ TL/ *	35	DL/ 28/ USB/ C	124	GA/ 58	179
BA/ 5/ W1* *	94	BW/ 31L	66	CL/ 15/ W1* *	36/ 278	DL/ 4/ *	120	GA/ 59	178

* See suffix options on the relevant page.

Model No.	Page	Model No.	Page	Model No.	Page	Model No.	Page	Model No.	Page
GD/ 59/ W1	281	HA/ 100/ W2	212	LED/ 100/ *	12	LG/ 1/ *	170-171	MH/ 2/ F* *	82/ 234
GG/ 14/ 10	259	HI/ 135/ W1	282	LED/ 10A/ *	10	LG/ 17* *	227	MH/ 2/ W1* *	82
GG/ 14/ 10+5	259	HI/ 59/ 16	282	LED/ 10A/ USB* *	110/ 125	LG/ 2/ *	172-173	MT/ 13/ DL/ *	74
GG/ 14/ 6	258	HI/ 595/ 8	282	LED/ 300/ *	12	LG/ 3/ *	174-175	MT/ 13/ FS/ *	76
GG/ 14/ P	258	HO/ 3/ W1* *	275	LED/ 350/ *	12	LG/ 3F* *	228/ 230	MT/ 13/ FS3* *	76
GG/ 14/ W1	258	IC/ 24/ 12+6	203	LED/ 418/ *	13	LG/ 4/ *	176-177	MT/ 13/ W1* *	75
GG/ 14/ W2	258	IC/ 24/ 3+3	202	LED/ 418/ SW/ *	13	LG/ 5F* *	229-230	MT/ 13/ W1A* *	74
GN/ 950/ W2/ EZ	290	IC/ 24/ 6+6	204	LED/ 5/ 1* *	99-100	LN/ 34/ FS/ *	32-34	MY/ 12/ L/ *	289
GF 10	231	IC/ 24/ P	205	LED/ 5/ 1/ USB/ *	102/ 123/ 125	LN/ 34/ TL/ *	33-34	MY/ 12/ M/ *	288
GF 11	231	IC/ 24/ W2	205	LED/ 5/ 1W/ L* *	101	LN/ 34/ W1* *	32-34	MY/ 12/ S* *	288
GS/ 200/ CR	216-217	IN/ 12/ DL/ BNC	159	LED/ 5/ 1WR* *	101	LN/ 34/ W2/ *	32-34	MY/ 12/ W2/ *	288
GS/ 200/ OP	216-217	IN/ 12/ FS/ BNC	158	LED/ 5/ 2/ *	100	LN/ 34/ WW/ *	32-34/ 165	NL/ 44/ W2	281
GS/ 66/ SM	187	IN/ 12/ TL/ BNC	159	LED/ 5/ 2/ W1 USB/ *	104/ 125	LO/ 001 10	261	OD/ 30/ TL/ *	188
GU/ 5/ FS	150	IN/ 12/ W1/ BNC	158	LED/ 500/ *	12	LO/ 00110+5	260	OD/ 30/ W1* *	165/ 188/ 279
GU/ 5/ TL	151	IN/ 12/ W1 LED/ BNC	158	LED/ 6/ *	96-98	LO/ 0016	261	OR/ 4/ 10	209
GU/ 5/ W1	150	KL/ 100/ 3/ *	287	LED/ 7/ *	106-107	LO/ 001 W1	260	OR/ 4/ 6	208
GU/ 5/ W1/ LED	150	KL/ 100/ 6/ *	287	LED/ 750/ *	12	LO/ 001 W2	260	OR/ 4/ P	208
GX/ 102/ 1000/ 30+24+B	247	KL/ 100/ GS	287	LED/ 77/ *	105	LV/ 7165/ W	167	OR/ 4/ W1	208
GX/ 102/ 600/ B	246	KL/ 150/ GS	287	LED/ 7A/ *	106-107	MD/ 8/ FS2	47	OS/ 7/ TL	184
HA/ 100/ 10	211	LA/ 40/ F 100	245	LED/ 7A/ USB* *	107/ 125	MD/ 8/ P	47/ 234	OS/ 9/ TL	184
HA/ 100/ 4	210	LA/ 40/ W1 300x200	245	LED/ 8/ *	109	MD/ 8/ TL2	45	OX/ 42/ 3/ BFB	216
HA/ 100/ 8	210	LED/ 10/ *	10	LED/ 800/ *	12	MD/ 8/ W1	47/ 277	OX/ 42/ 6/ BFB	217
HA/ 100/ W1	212	LED/ 10/ W1* *	111	LED/ 9/ *	108	MD/ 8/ W2	46/ 277	OX/ 42/ W1 BFB	216
HA/ 100/ W1A	212	LED/ 10/ W2/ *	111	LED/ 9/ SW/ *	108	MH/ 2/ DL/ *	82-83	OX/ 42/ W2/ BFB	217

* See suffix options on the relevant page.

Model No.	Page	Model No.	Page	Model No.	Page	Model No.	Page	Model No.	Page
FA/ 18/ TL	189	FL/8/ 550/ *	284	QBE/ W1*	129	QEX/ FS1*	138	QSH/ 12/ *	50
FA/ 18/ W1	189/279	PM/ 28/ 650/ P	255	QBR/ *	293	QEX/ FS2/ *	138	QSH/ 6/ *	48-50
FB/ 10/ W1	281	PM/ 28/ 800/ P	255	QBR/ 10H	253	QEX/ TL/ *	139	QSR/ 10/ *	136
FB/4/ W1	281	PM/ 28/ W2	254	QBR/ 14H	253	QFA/ 70/ *	198	QSR/ 6/ *	136-137
FB/ 50/ BN	280	FR/ 24/ TL	191	QBW/ 6/ W/C	164	QFD/ *	292	QST/ *	292
FB/ 70/ W1 BN	280	FR/ 24/ W1	191	QBX/ FS*	132	QGG/ 8/ *	258-259	QTC/ *	293
FE/60/ BL/ COP	235	FX/ 14/ 5P	213	QBX/ F*	132	QKE/ *	293	QTR/ FS*	140
FI/ 38/ FS	127	FX/ 14/ P	213	QBX/ TL*	133	QLD/ *	111	QTR/ TL*	141
FI/38/ TL	127	FZ/4/ FS	157	QBX/ W1*	132	QMD/2/ *	45-46	QTR/ W1*	140-141
FI/38/ W1	127	FZ/4/ TL	157	QCHB/ 14/ *	130-131	QMD/ CYL/ L/ NP	47	QTR/ W1 SHORT/ *	140
FI/9/ DL/ C	155	FZ/4/ W1	157	QCHB/ 18/ *	131	QMD/ CYL/ NP	45-47	QTV/ TL/ *	126
FI/9/ FS/ C	154	Q009/ *	190	QCO/ 6/ *	251	QMD/ FS/ SM	47	QTV/ W1*	126
FI/9/ RL/ C	154	Q110/ FS/ *	70-71	QCS/ *	236	QMD/ F/ SM	47	QTW/ 5/ *	192-193
FI/9/ TL/ BL/ BRB	156	Q110/ TL/ *	70-73	QCY/ *	292	QMD/ W1/ SM	47	QTW/ 9/ *	192
FI/9/ TL/ C	155	Q110/ W1*	72	QCY/ GGF*	258	QOB/ *	293	QTY/ F/ OY	58
FI/9/ TL/ LED/ C	155	Q12/ *	118	QDL/ 7/ *	55	QPK/ 10/ *	84-85	QWA/ 12/ *	196
FI/9/ TL/ USB/ C	124/ 156	Q22/ FS/ *	67	QDR/ M/ BB*	95	QPK/ 12/ *	84-85	QWA/ 18/ *	196
FI/9/ W1/ C	154	Q22/ TL/ *	65	QDR/ 8/ *	95	QPK/ 16/ *	84-85	QWE/ 200/ *	266
FK/ 16/ FS*	84-85	Q22/ W1*	66	QDW/ 10/ *	146	QFR/ W1*	191	QWE/ 700/ *	266
FK/ 16/ TL/ *	84-85	Q26B/ *	274	QDW/ 5/ *	146-147	QRTS/ *	292	RA/ 4/ DL	41
FK/ 16/ W1*	84-85	Q5L/ *	101	QEL/ *	292	QSG/ 7/ HE	62-63	RA/ 4/ P	40/ 220
FL/ 6/ 300/ *	285	Q5R/ *	101	QEL/ 12H/ *	250	QSG/ 7/ OY	64	RA/ 4/ W1	40/ 220
FL/ 6/ 550/ *	285	Q5USB/ *	104	QEL/ 20H/ *	250	QSG/ W1 HE	62	RA/ 4/ W2	40/ 220/ 277
FL/ 8/ 300/ *	284	Q9/ 7/ *	190	QEX/ DL/ *	139	QSG/ W1 OY	64	RA/ 5/ W1	40/ 220

* See suffix options on the relevant page.

Model No.	Page	Model No.	Page	Model No.	Page	Model No.	Page	Model No.	Page
FG/ 3/ 6/ *	222	SE/ 14/ DL/ *	77	SN/ 28/ 250	269	SN/ 39/ W1*	88-89	UR/ 6/ W1 LED/ C/ CH	160
FG/ 3/ W1*	165/ 222	SE/ 14/ FS*	78	SN/ 28/ 300	269	SN/ 40/ FS*	87	VY/ 78/ FS	148
FI/ 23/ FS*	68-69	SE/ 14/ F*	78/ 234	SN/ 28/ 600	269	SN/ 40/ TL*	86-87	VY/ 78/ TL	148
FI/ 23/ TL*	68-69	SE/ 14/ W1*	79	SO/ 34/ W1	278	SN/ 40/ TL/ EBR/ STONE	15	VY/ 78/ W1	148
FI/ 23/ W1*	68-69	SG/ 24/ FS/ BB	60	SP/ 32/ 500	286	SN/ 40/ W1*	86	WA/ 31/ FS	196
FK/ 10/ FS	56	SG/ 24/ F/ BB	60/ 232	SP/ 32/ 800	286	TD/ 3/ 3P	249	WA/ 31/ TL	196
FK/ 10/ TL	56	SG/ 24/ TL/ BB	61	SP/ 32/ W2	286	TD/ 3/ P	249	WE/ 10/ 200	266
FK/ 10/ W1	56/ 276	SG/ 24/ W1/ BB	60/ 276	SR/ 15/ FS*	136	TO/ 10/ FS*	92-93	WE/ 10/ 700	266
FK/ 11/ TL	57	SG/ 25/ F*	62-64/ 232	SR/ 15/ TL*	136-137	TO/ 10/ TL*	92-93	WE/ 3600/ W	267
FM/ 9/ FS	38	SG/ 25/ TL*	63-64	SS/ 12/ W1	253	TR/ 4/ FS*	140	WE/ CON/ 750/ GM	267
FM/ 9/ P	38	SG/ 25/ W1*	62-64/ 280	SS/ 18/ W1	253	TR/ 4/ TL*	141	WE/ O/ 600/ TP	267
FM/ 9/ TL	39	SH/ 60/ FS2/ *	50	SS21/ S1/ IVFL	252	TR/ 4/ W1*	140-141	WE/ O/ 750/ DU	267
FM/ 9/ W1	38/ 276	SH/ 60/ TL2/ *	48-49	SS/ 3/ W1	283	TR/ 4/ W1 LED*	140	WK/ 70/ FS	149
FO/ 42/ P	241	SH/ 60/ W1/ *	50	SS/ 67/ W1	250	TV/ 36/ TL*	126	WK/ 70/ TL	149
FO/ 42/ 28+8	241	SH/ 60/ W2/ *	48/ 277	SS/ 80/ 4P	252	TV/ 36/ W1 LED*	126	WK/ 70/ W1	149
FR/ 30/ W1*	272	SK/ 24/ BN	183	SS/ 80/ W1	253/ 280	TW/ 58/ FS/ *	192	WL/ 28/ *	122
FR/ 30/ W1/ *	272/ 279	SK/ 24/ EBR	180	SS/ 90/ 6+3	251	TW/ 58/ TL*	192-193	WT/ 23/ FS/ BB/ EBR	52
SA/ 28/ 900/ F	264	SK/ 26/ BN	182	SS/ 90/ 8+4	251	TW/ 58/ W2*	192	WT/ 23/ TL/ BB/ EBR	53
SA/ 28/ 900/ P	264	SK/ 26/ EBR	180	SS/ 90/ FS	194/ 253	TY/ 10/ P	58/ 233	WT/ 23/ W1/ BB/ EBR	52
SA/ 29/ 600/ P	265	SK/ 27/ *	180-183	SS/ 90/ TL	194/ 253	TY/ 10/ TL	58-59		
SA/ 30/ W2	265	SK/ 28/ BN	183	SS/ 90/ W2	250	TY/ 10/ W1	58/ 279		
SB/ 44/ 6	206	SL/ 11/ W1	270	SS/ 93/ W1	250	UR/ 6/ FSC/ CH	160		
SB/ 44/ 8	207	SL/ 12/ TL	270	SN/ 39/ FS*	88-89	UR/ 6/ TL/ C/ CH	161		
SC/ 26B/ BL	274	SL/ 12/ W1	271	SN/ 39/ TL*	88-89	UR/ 6/ W1/ C/ CH	160		

* See suffix options on the relevant page.

CONVERSION CHART

(millimetres to inches)

NOTES

mm	inches	mm	inches	mm	inches	mm	inches
10	0.4	510	20.1	1010	39.8	1510	59.4
20	0.8	520	20.5	1020	40.2	1520	59.8
30	1.2	530	20.9	1030	40.6	1530	60.2
40	1.6	540	21.3	1040	40.9	1540	60.6
50	2.0	550	21.7	1050	41.3	1550	61.0
60	2.4	560	22.0	1060	41.7	1560	61.4
70	2.8	570	22.4	1070	42.1	1570	61.8
80	3.1	580	22.8	1080	42.5	1580	62.2
90	3.5	590	23.2	1090	42.9	1590	62.6
100	3.9	600	23.6	1100	43.3	1600	63.0
110	4.3	610	24.0	1110	43.7	1610	63.4
120	4.7	620	24.4	1120	44.1	1620	63.8
130	5.1	630	24.8	1130	44.5	1630	64.2
140	5.5	640	25.2	1140	44.9	1640	64.6
150	5.9	650	25.6	1150	45.3	1650	65.0
160	6.3	660	26.0	1160	45.7	1660	65.4
170	6.7	670	26.4	1170	46.1	1670	65.7
180	7.1	680	26.8	1180	46.5	1680	66.1
190	7.5	690	27.2	1190	46.9	1690	66.5
200	7.9	700	27.6	1200	47.2	1700	66.9
210	8.3	710	28.0	1210	47.6	1710	67.3
220	8.7	720	28.3	1220	48.0	1720	67.7
230	9.1	730	28.7	1230	48.4	1730	68.1
240	9.4	740	29.1	1240	48.8	1740	68.5
250	9.8	750	29.5	1250	49.2	1750	68.9
260	10.2	760	29.9	1260	49.6	1760	69.3
270	10.6	770	30.3	1270	50.0	1770	69.7
280	11.0	780	30.7	1280	50.4	1780	70.1
290	11.4	790	31.1	1290	50.8	1790	70.5
300	11.8	800	31.5	1300	51.2	1800	70.9
310	12.2	810	31.9	1310	51.6	1810	71.3
320	12.6	820	32.3	1320	52.0	1820	71.7
330	13.0	830	32.7	1330	52.4	1830	72.0
340	13.4	840	33.1	1340	52.8	1840	72.4
350	13.8	850	33.5	1350	53.1	1850	72.8
360	14.2	860	33.9	1360	53.5	1860	73.2
370	14.6	870	34.3	1370	53.9	1870	73.6
380	15.0	880	34.6	1380	54.3	1880	74.0
390	15.4	890	35.0	1390	54.7	1890	74.4
400	15.7	900	35.4	1400	55.1	1900	74.8
410	16.1	910	35.8	1410	55.5	1910	75.2
420	16.5	920	36.2	1420	55.9	1920	75.6
430	16.9	930	36.6	1430	56.3	1930	76.0
440	17.3	940	37.0	1440	56.7	1940	76.4
450	17.7	950	37.4	1450	57.1	1950	76.8
460	18.1	960	37.8	1460	57.5	1960	77.2
470	18.5	970	38.2	1470	57.9	1970	77.6
480	18.9	980	38.6	1480	58.3	1980	78.0
490	19.3	990	39.0	1490	58.7	1990	78.3
500	19.7	1000	39.4	1500	59.1	2000	78.7

To convert millimetres to inches: millimetres x 0.03937

To convert inches to millimetres: inches x 25.4



